

Sacramento 10S

Phoenix 10S

MP BUILD

2008 0123

DATE	CHANGE NO.	REV

DRAWER	EE	DATE	POWER	DATE	INVENTEC			
DESIGN					TITLE PS10S			
CHECK								
RESPONSIBLE								
SIZE =	3			VER :				
FILE NAME :	XXXX XXXXXX-XX				SIZE	CODE	DOC. NUMBER	REV
P/N	XXXXXXXXXXXX				A3	CS	Model No	X01
					SHEET	1	OF	63

TABLE OF CONTENTS

PAGE	PAGE	PAGE
1.COVER PAGE	33. HDMI TRANSMITTER	58.MDC 1.5 CONN
2.INDEX	34.S/B ICH8 1	59.LED(M/B) & HOTKEY/B CONN
3.BLOCK DIAGRAM	35.S/B ICH8 2	60.PICK BUTTON BOARD
4.POWER SEQUENCE BLOCK	36.S/B ICH8 3	61.KILL SWITCH& HALL SENSOR
5-12.SYSTEM POWER	37.S/B ICH8 4	62.DRILL HOLE
13.CLOCK GENERATOR	38.S/B ICH8 5	63.EMI
14.CPU Merom1	40.3 IN 1 CARD SLOT	
15.CPU Merom2	41.CARDBUS CONTROLLER	
16.CPU Merom3	42.PCMCIA CONN	
17.CPU Merom4		
18.FAN & THERMAL CONTROLLER	43.EXPRESS CARD CONN	
19.N/B Crestline 1	44.LAN CONTROLLER	
20.N/B Crestline 2	45.RJ45 & TRANSFORMER	
21.N/B Crestline 3	46.ROBSON & WLAN	
22.N/B Crestline 4	47.SATA HDD1 CONN	
23.N/B Crescline 5	48.CAMERA CONN	
24.N/B Crestline 6	49.ODD CONN	
25.N/B Crestline 7	50.USB CONN	
26.DDR2 DIMM0	51. N/A	
27.DDR2 DIMM1	52.HD_DVD	
28.DDR DAMPING	53.KBC	
29.N/A	54.K/B & TP/B CONN	
30.CRT CONN	55.HDMI CONN	
31.N/A	56.AZALIA CODEC	
32.LCM CONN	57.AUDIO AMP & MIC & HP	

INVENTEC			
TITLE <i>PS10S</i>			
SIZE A3	CODE CS	DOC. NUMBER <i>Model No</i>	REV X01
CHANGE by <i>IEC951098</i>		28-Aug-2007	
SHEET		2	OF 63

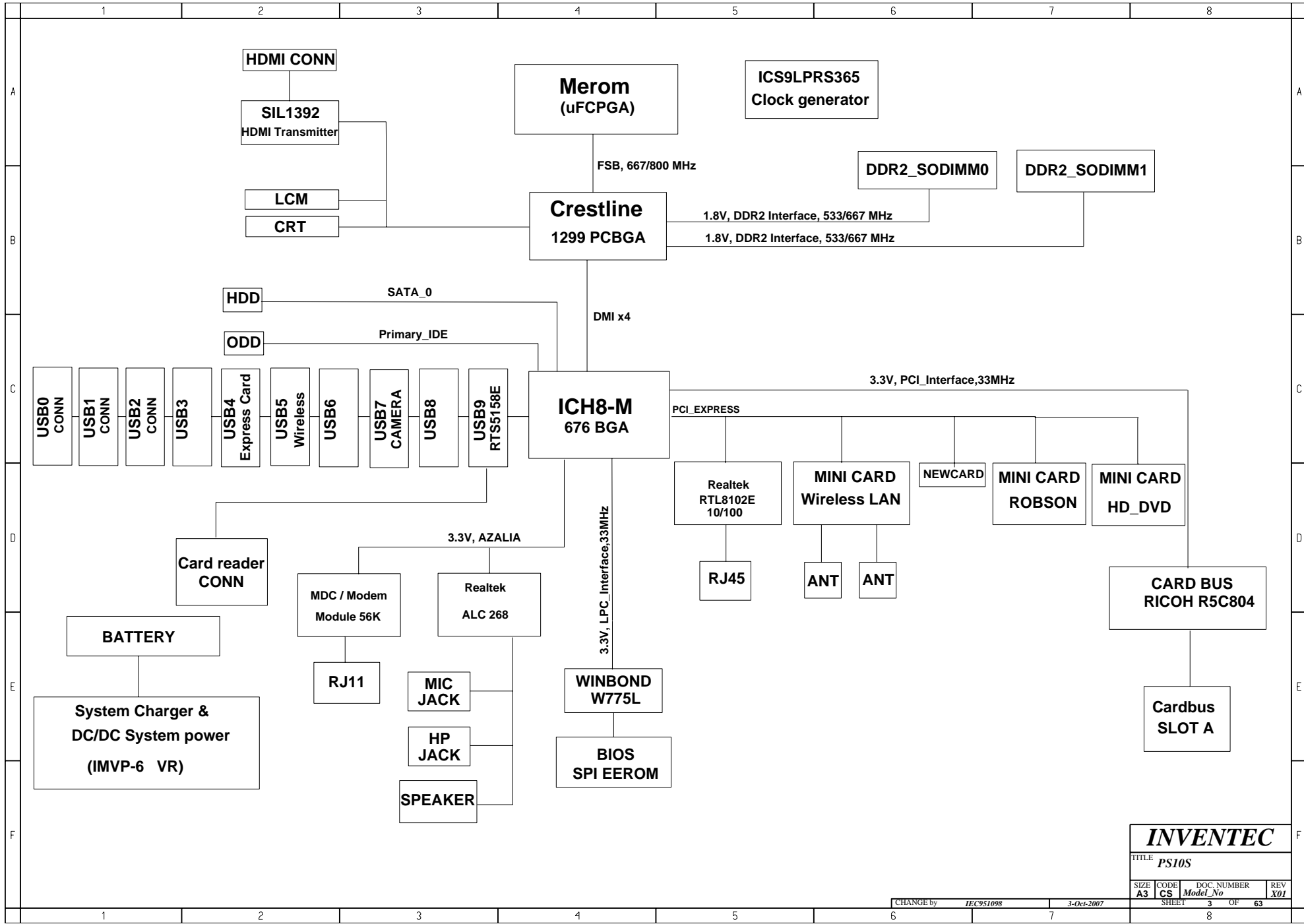

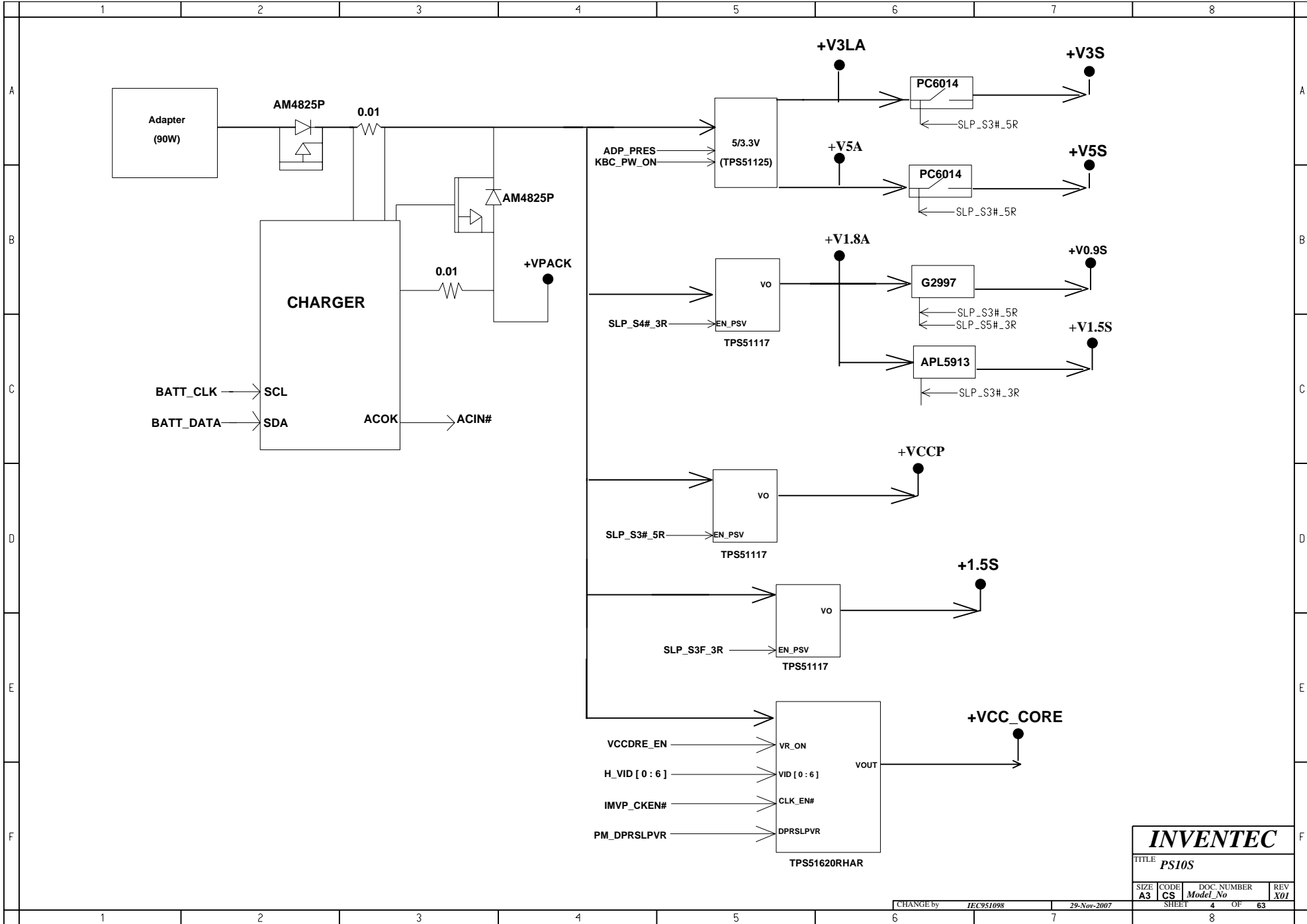

INVENTEC			
TITLE PS10S			
SIZE A3	CODE CS	DOC. NUMBER <i>Model_No</i>	REV X01
CHANGE by IEC951098		29-Nov-2007	
SHEET 4		OF 63	

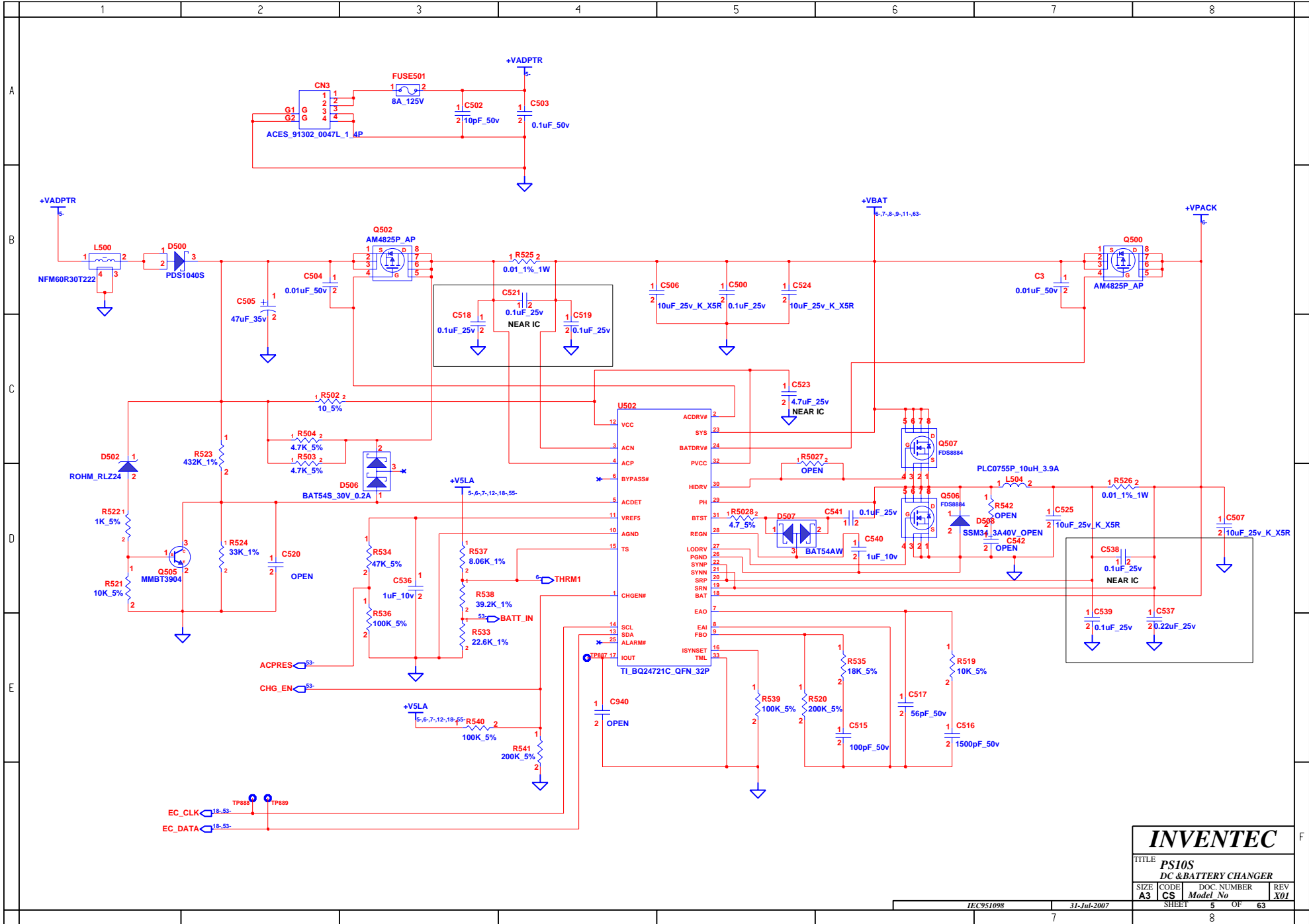

INVENTEC

TITLE
PS10S
DC & BATTERY CHANGER

SIZE	CODE	DOC. NUMBER	REV
A3	CS	Model_No	X01

IEC951098

31-Jul-2007

SHEET 5 OF 63

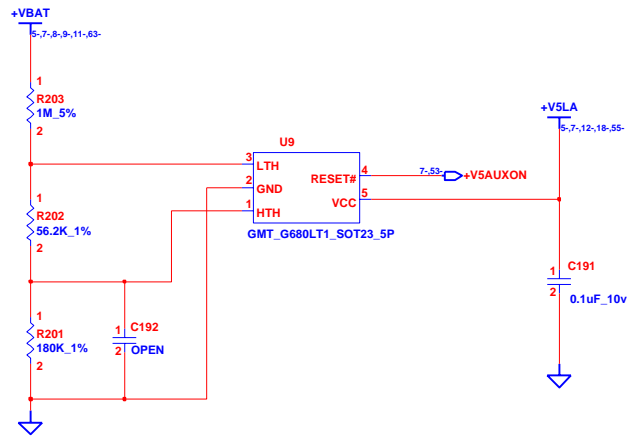
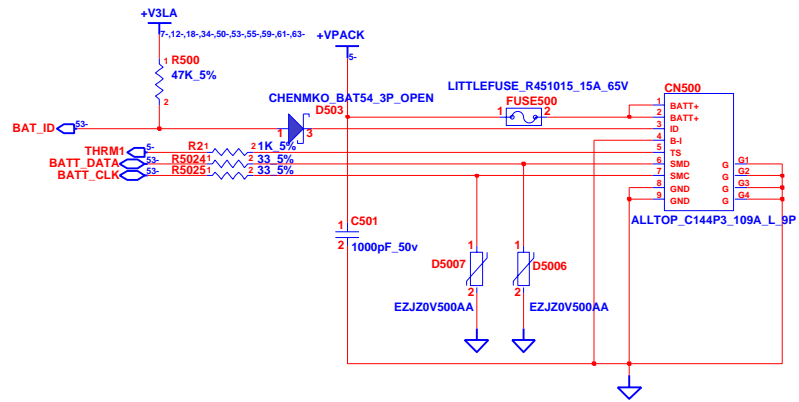

INVENTEC

TITLE			
PS10S BATTERY CONN			
SIZE	CODE	DOC. NUMBER	REV
A3	CS	Model No	X01

CHANGE by IEC951098

31-Jul-2007

SHEET 6 OF 63

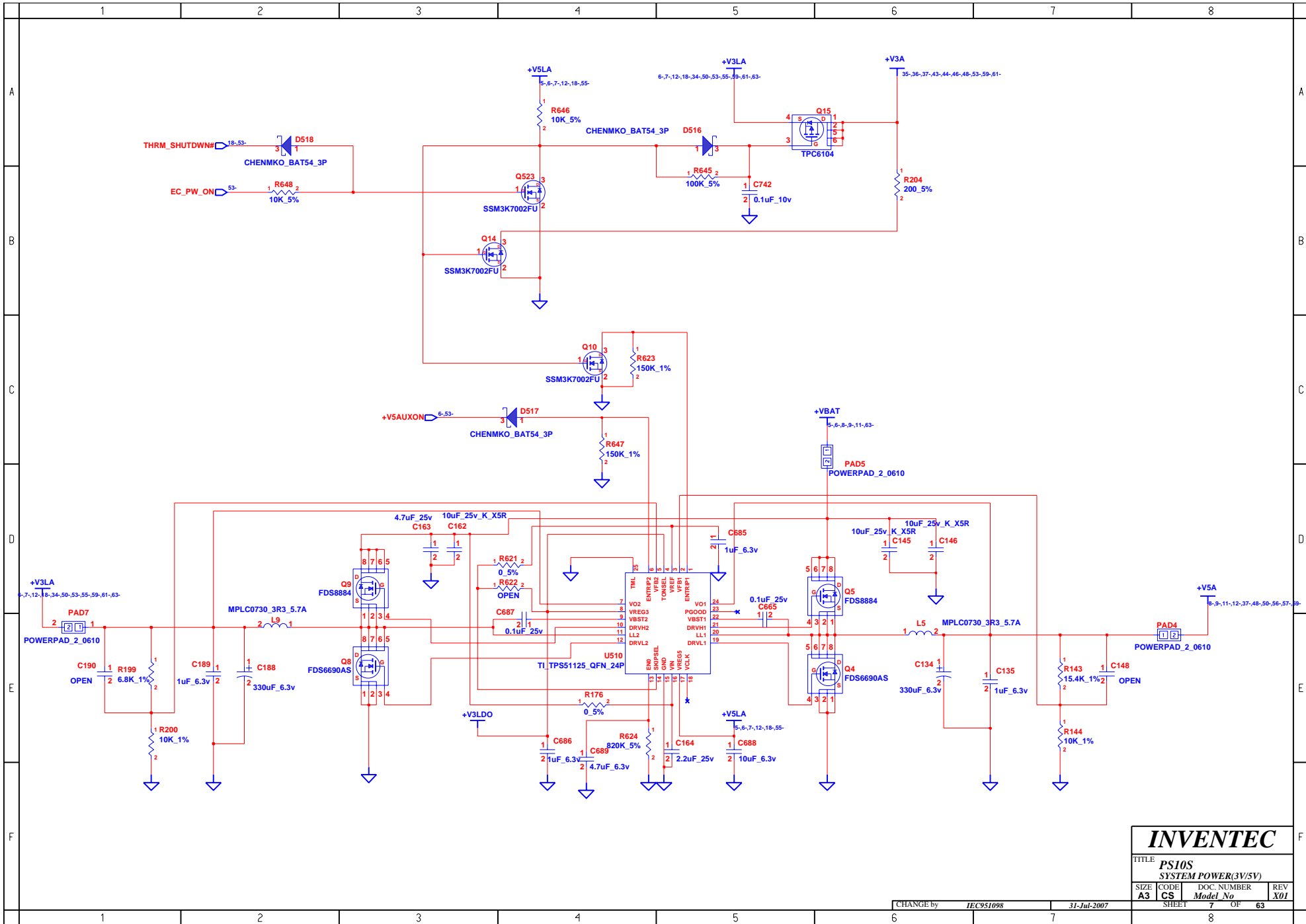

INVENTEC

TITLE
**PS10S
 SYSTEM POWER(3V/5V)**

SIZE A3	CODE CS	DOC. NUMBER <i>Model No</i>	REV X01
-------------------	-------------------	--------------------------------	-------------------

CHANGE by	IEC951098	31-Jul-2007
-----------	-----------	-------------

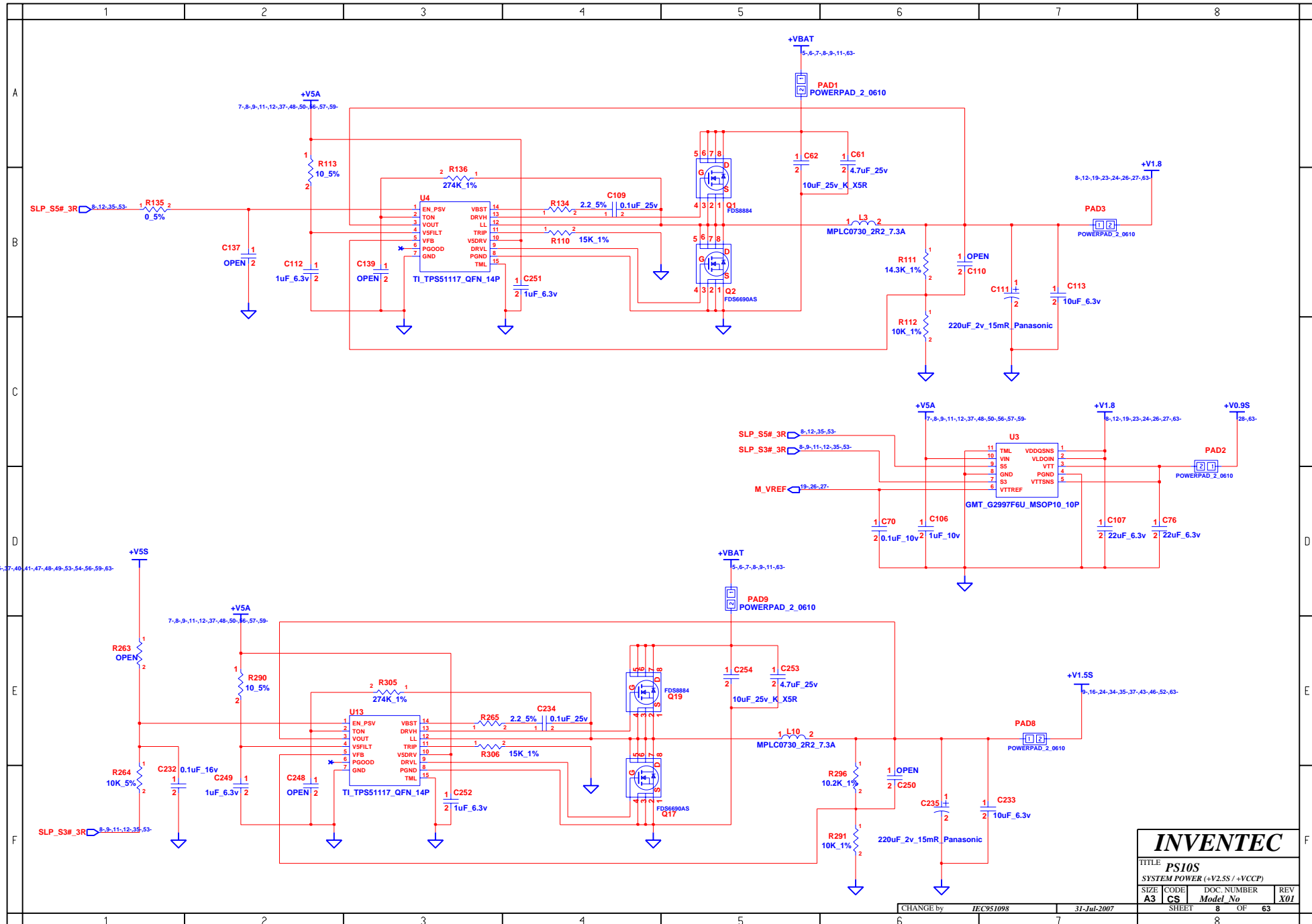

INVENTEC

TITLE **PS10S**
 SYSTEM POWER (+V2.SS / +VCCP)

SIZE A3	CODE CS	DOC. NUMBER Model No	REV X01
----------------	----------------	-----------------------------	----------------

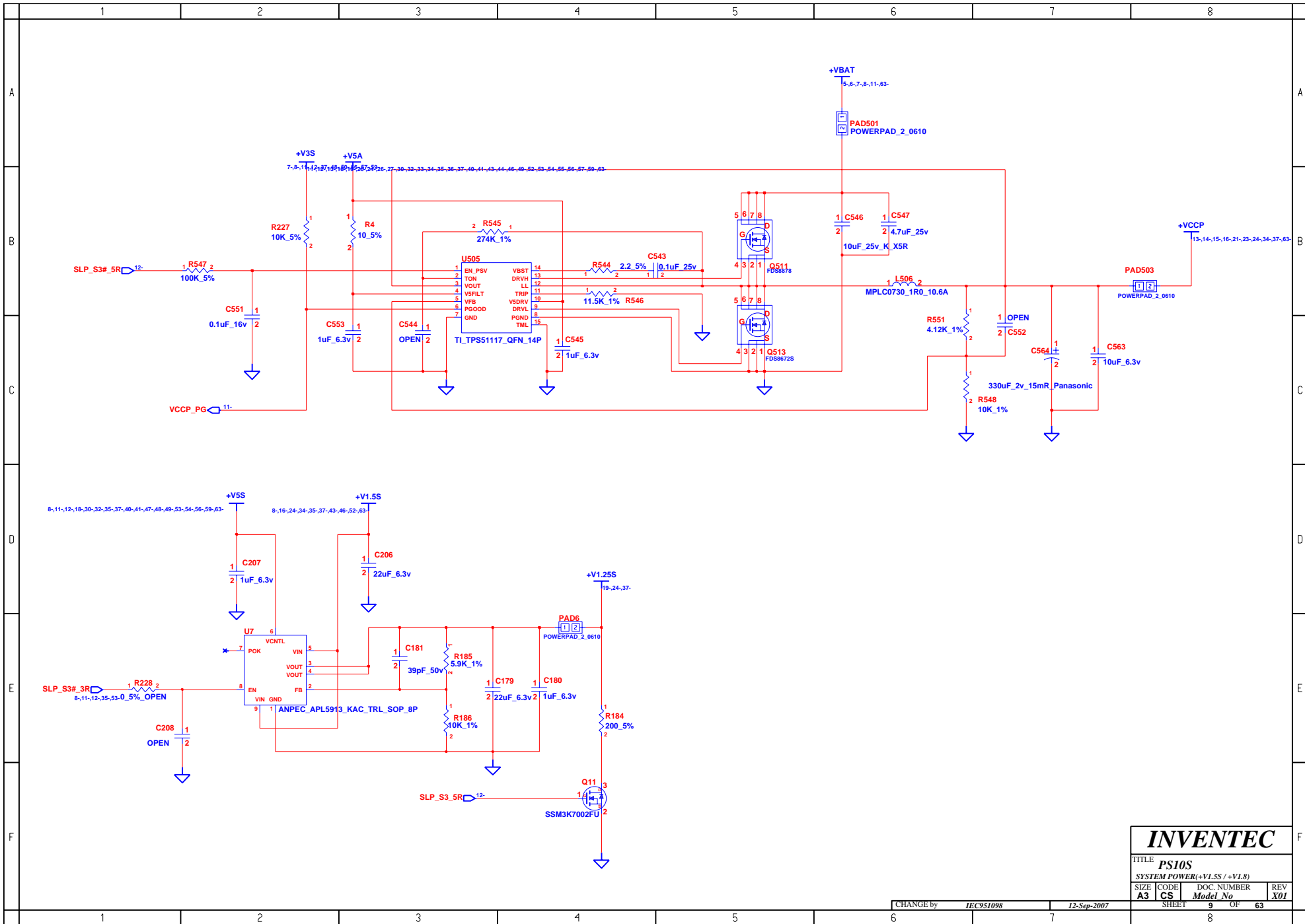

INVENTEC

TITLE			
PS10S			
SYSTEM POWER(+V1.5S / +V1.8)			
SIZE	CODE	DOC. NUMBER	REV
A3	CS	Model No	X01

CHANGE by	IEC951098	12-Sep-2007	SHEET	9	OF	63
				8		

BLANK

INVENTEC

TITLE			
<i>PS10S</i>			
<i>CPU POWER(VCC_CORE)</i>			
SIZE	CODE	DOC. NUMBER	REV
A3	CS	<i>Model No.</i>	X01
SHEET		10	OF 63

CHANGE by *IEC951098* 30-Nov-2007

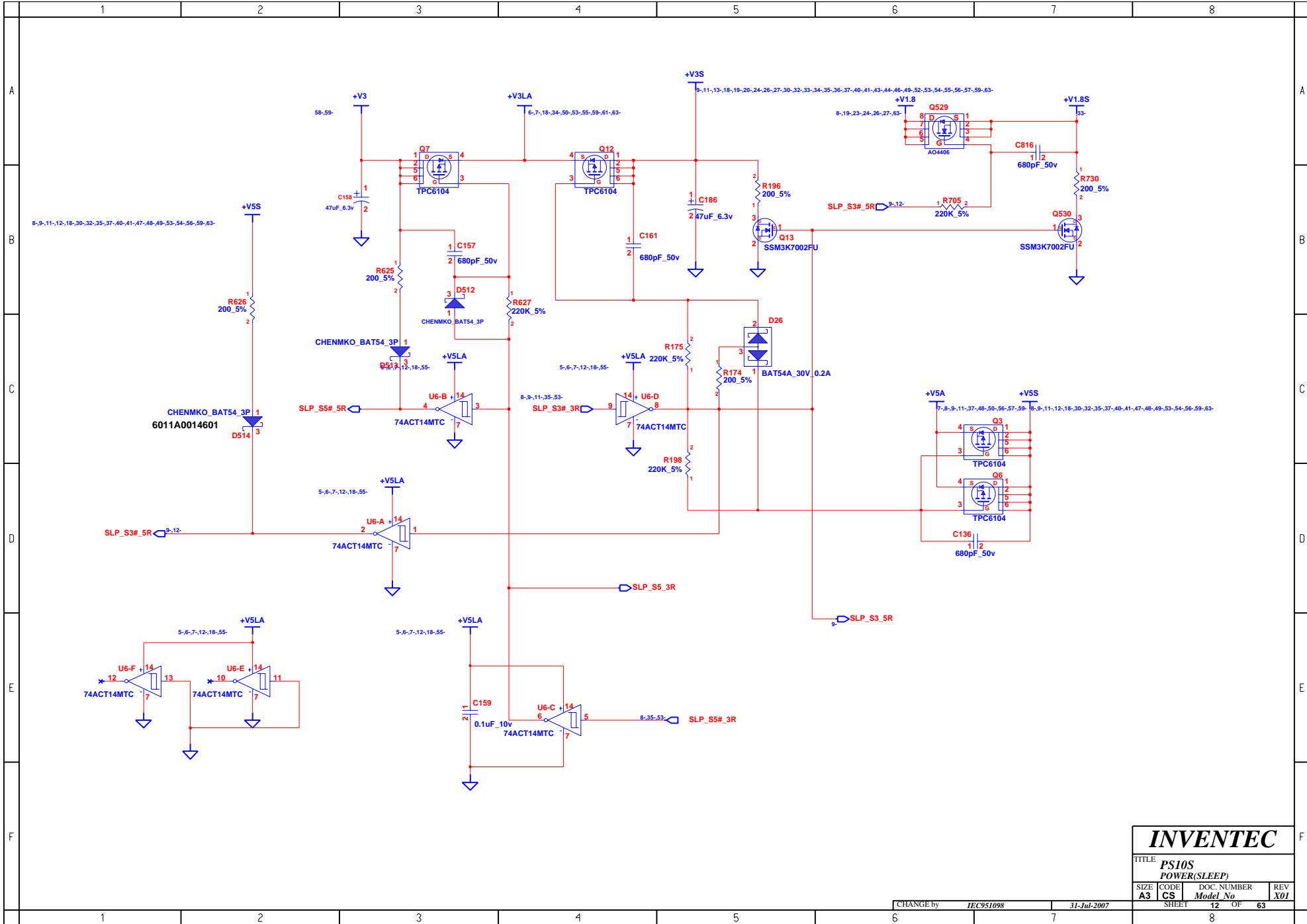

INVENTEC

TITLE			
PS10S			
POWER(SLEEP)			
SIZE	CODE	DOC. NUMBER	REV
A3	CS	Model No	X01

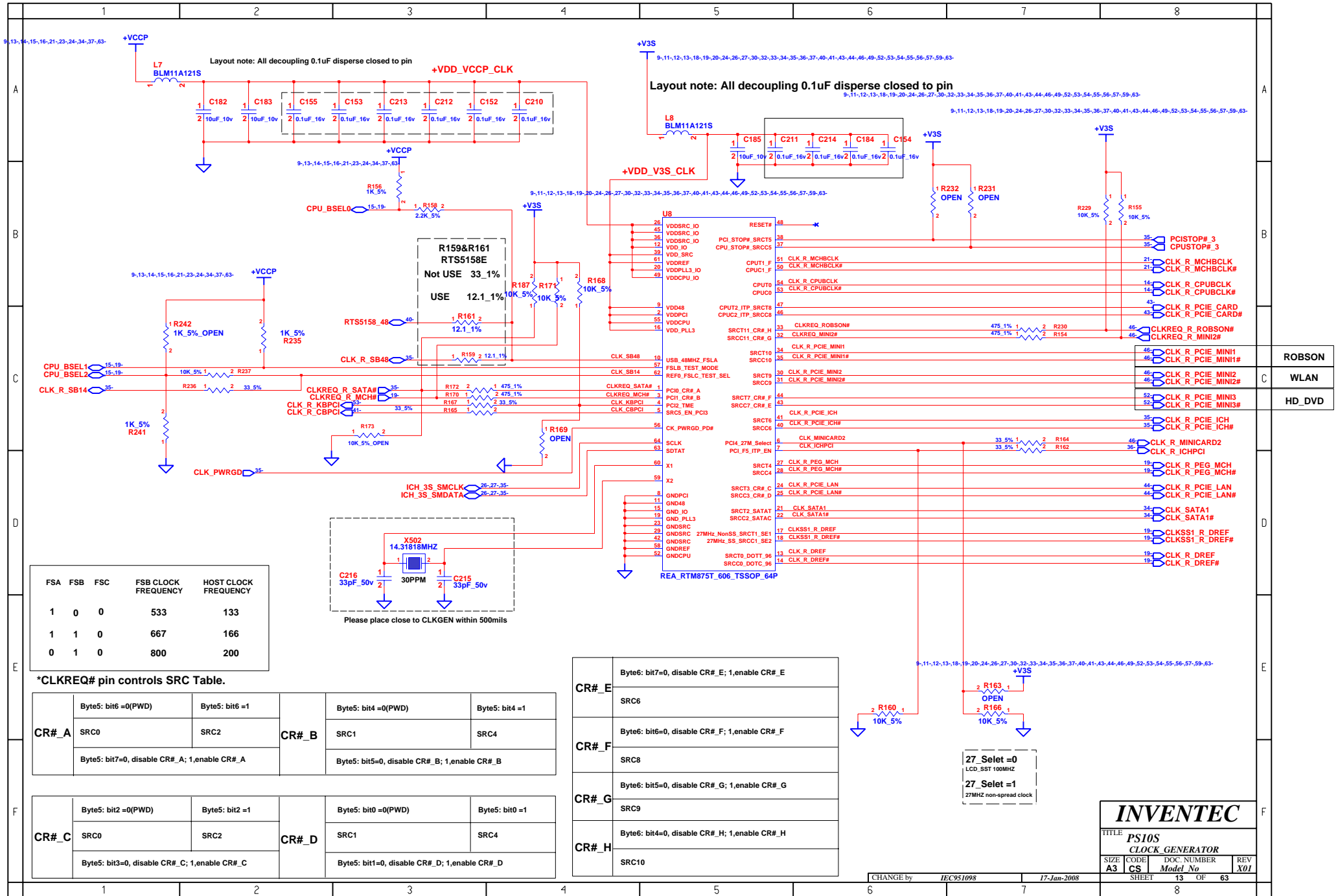

Layout note: All decoupling 0.1uF disperse closed to pin

Layout note: All decoupling 0.1uF disperse closed to pin

FSA	FSB	FSC	FSB CLOCK FREQUENCY	HOST CLOCK FREQUENCY
1	0	0	533	133
1	1	0	667	166
0	1	0	800	200

*CLKREQ# pin controls SRC Table.

CR#_A	Byte5: bit6 =0(PWD)		Byte5: bit6 =1	
	SRC0	SRC2	SRC1	SRC4
			CR#_B	
Byte5: bit7=0, disable CR#_A; 1,enable CR#_A			Byte5: bit5=0, disable CR#_B; 1,enable CR#_B	

CR#_C	Byte5: bit2 =0(PWD)		Byte5: bit2 =1	
	SRC0	SRC2	SRC1	SRC4
			CR#_D	
Byte5: bit3=0, disable CR#_C; 1,enable CR#_C			Byte5: bit1=0, disable CR#_D; 1,enable CR#_D	

CR#_E	Byte6: bit7=0, disable CR#_E; 1,enable CR#_E
SRC6	
CR#_F	Byte6: bit6=0, disable CR#_F; 1,enable CR#_F
SRC8	
CR#_G	Byte6: bit5=0, disable CR#_G; 1,enable CR#_G
SRC9	
CR#_H	Byte6: bit4=0, disable CR#_H; 1,enable CR#_H
SRC10	

27 Selet =0
LCD_SST 100MHZ

27 Selet =1
27MHZ non-spread clock

INVENTEC

TITLE PS10S
CLOCK GENERATOR

SIZE A3	CODE CS	DOC NUMBER Model No	REV X01
---------	---------	---------------------	---------

SHEET 13 OF 63

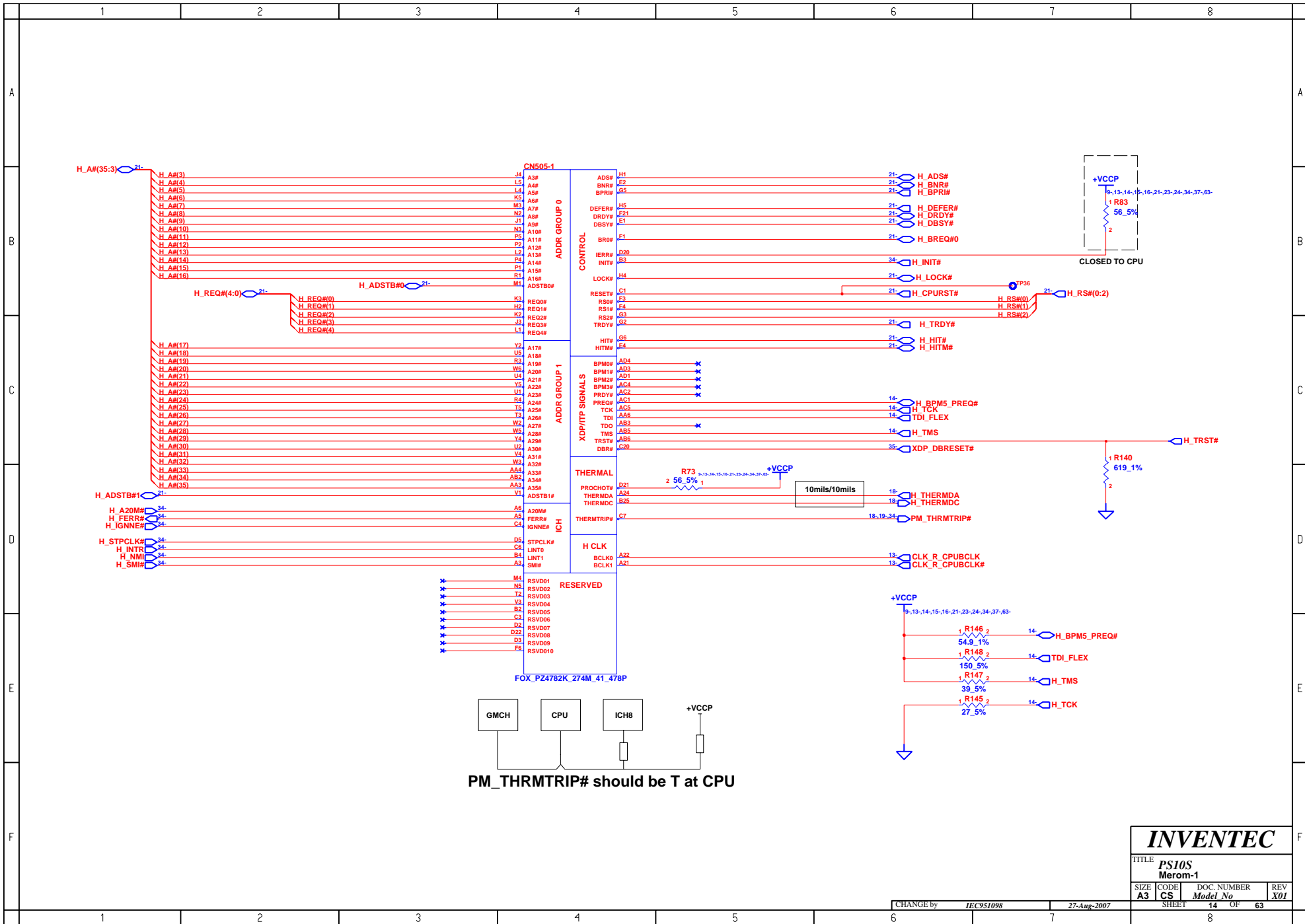

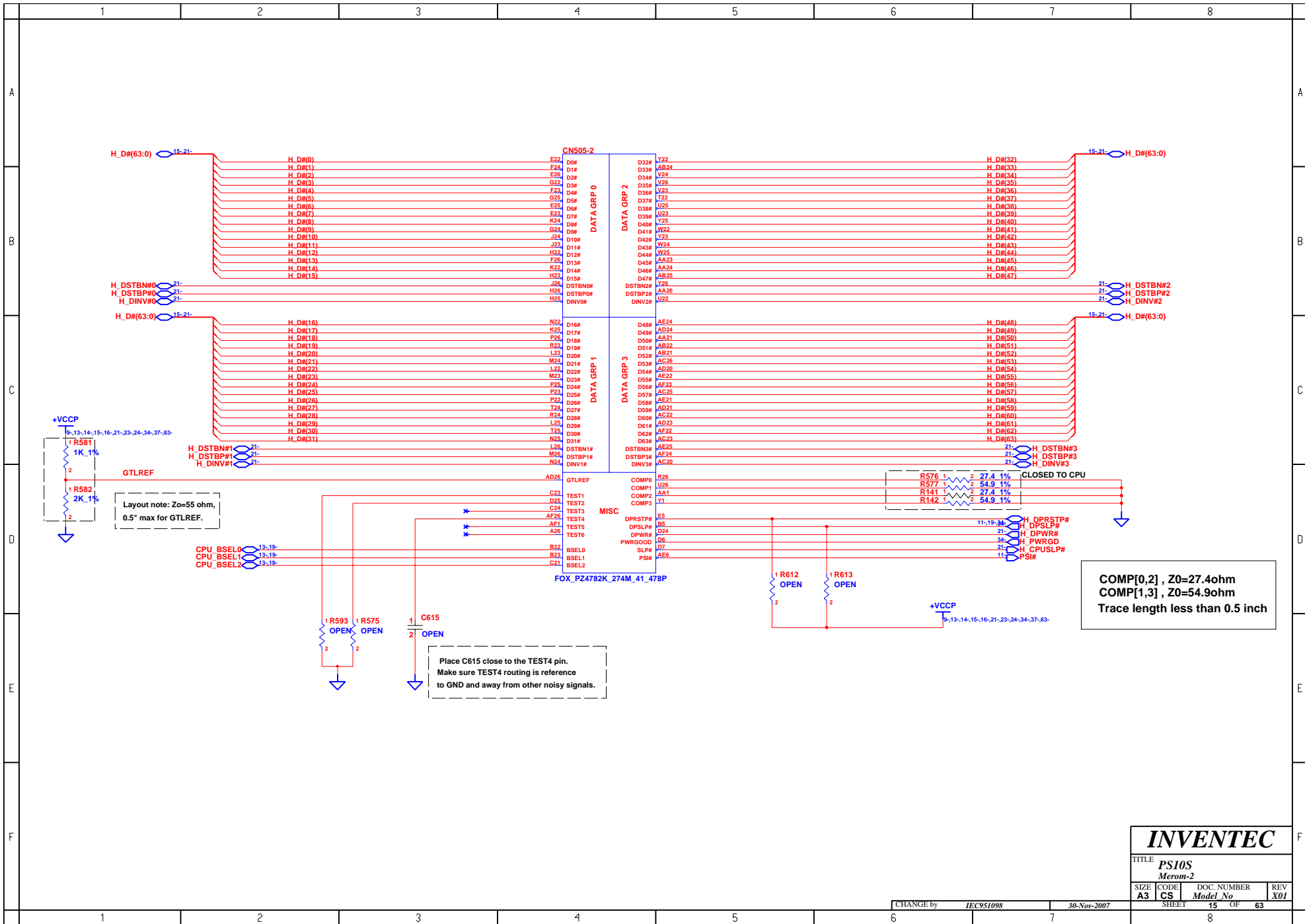

COMP0[0,2], Z0=27.4ohm
 COMP1[3], Z0=54.9ohm
 Trace length less than 0.5 inch

Place C615 close to the TEST4 pin.
 Make sure TEST4 routing is reference
 to GND and away from other noisy signals.

Layout note: Zo=55 ohm,
 0.5" max for GTLREF.

INVENTEC

TITLE PS10S
 Merom-2

SIZE	CODE	DOC. NUMBER	REV
A3	CS	Model No	X01

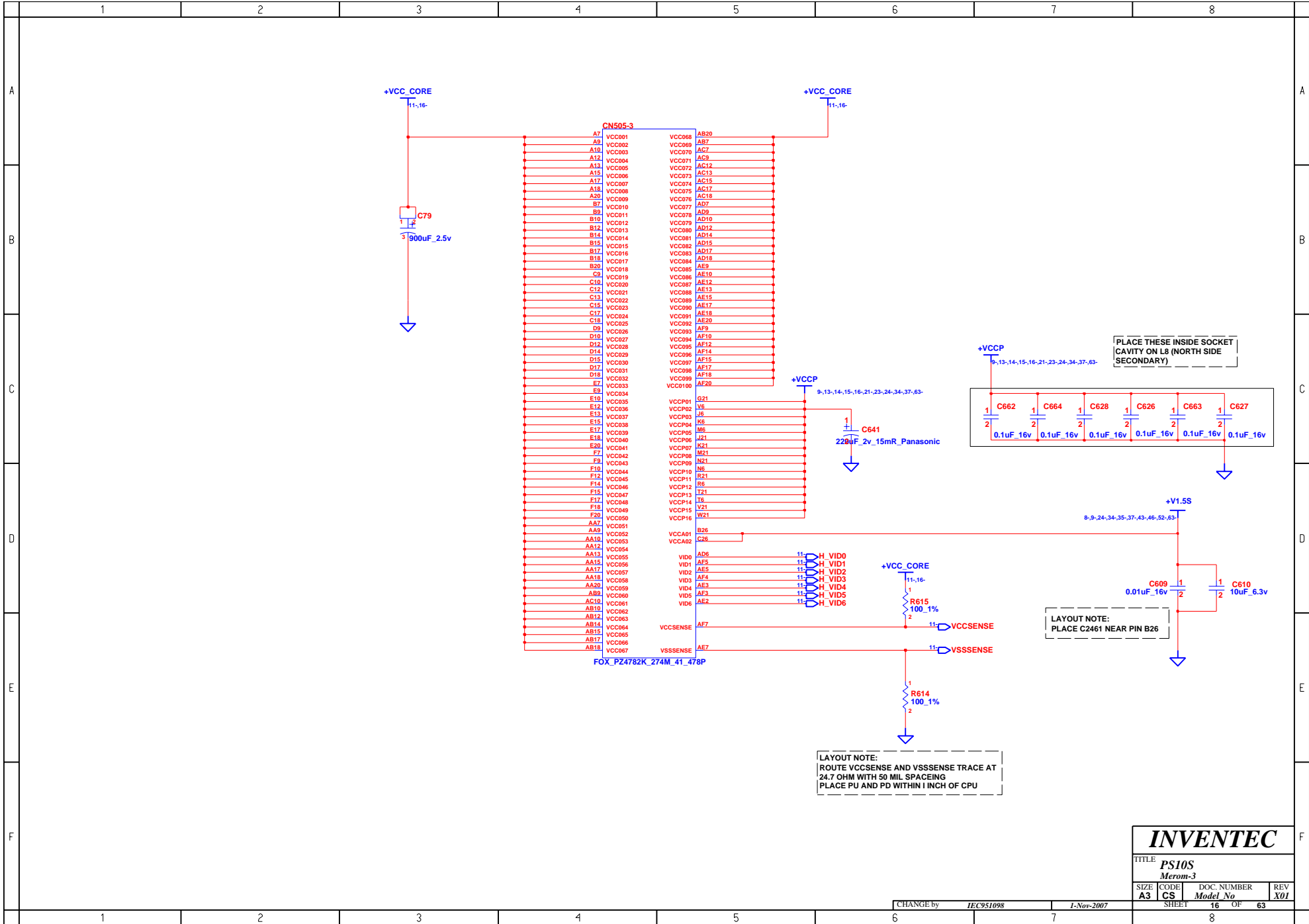

INVENTEC

TITLE			
PS10S			
Merom-3			
SIZE	CODE	DOC. NUMBER	REV
A3	CS	Model No	X01

CHANGE by	IEC951098	J-Nov-2007	SHEET	16	OF	63
-----------	-----------	------------	-------	----	----	----

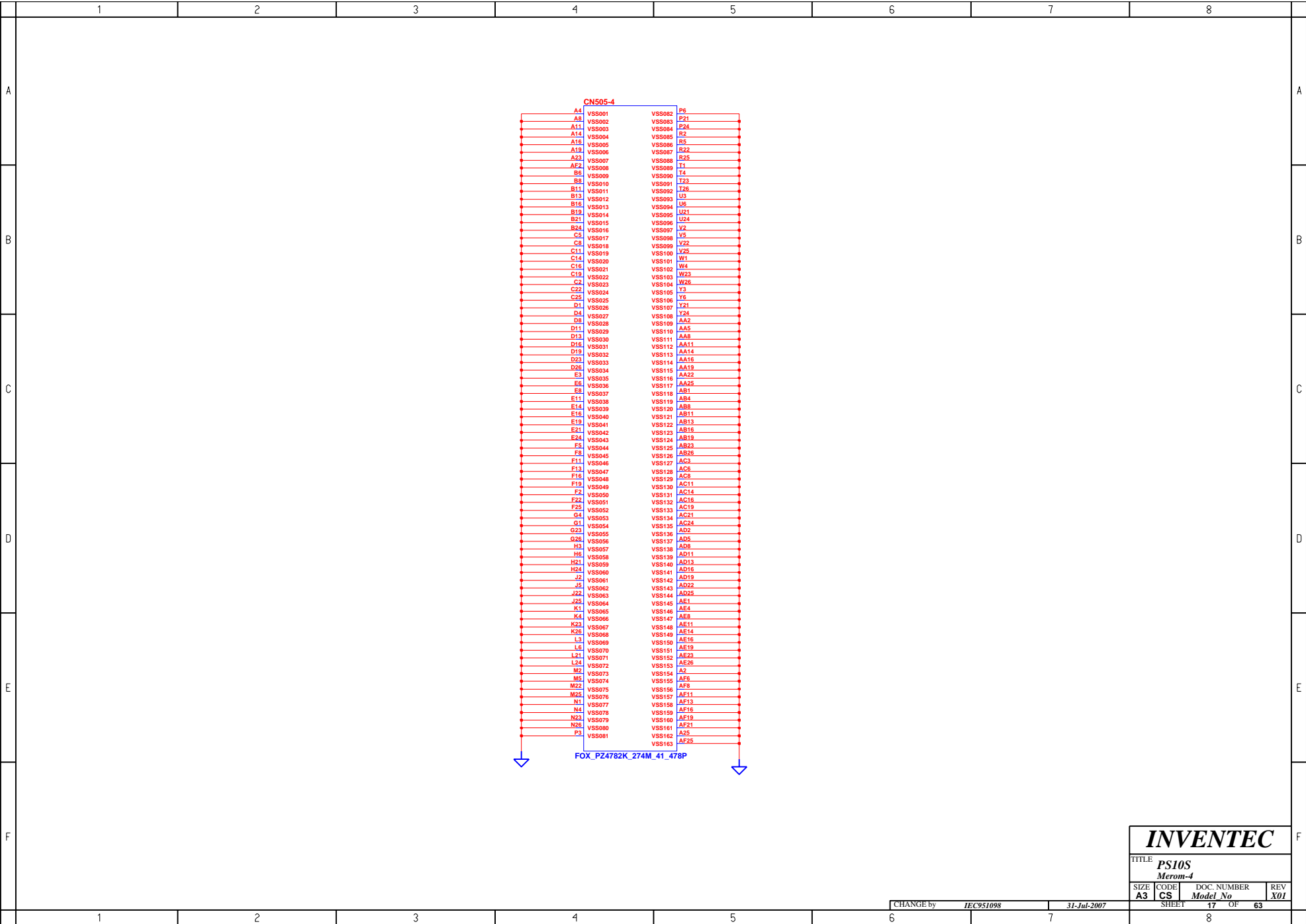

INVENTEC			
TITLE <i>PS10S</i>			
<i>Merom-4</i>			
SIZE	CODE	DOC. NUMBER	REV
A3	CS	<i>Model No</i>	X01
CHANGE by		SHEET	OF
<i>IEC951098</i>		17	63
31-Jul-2007		8	

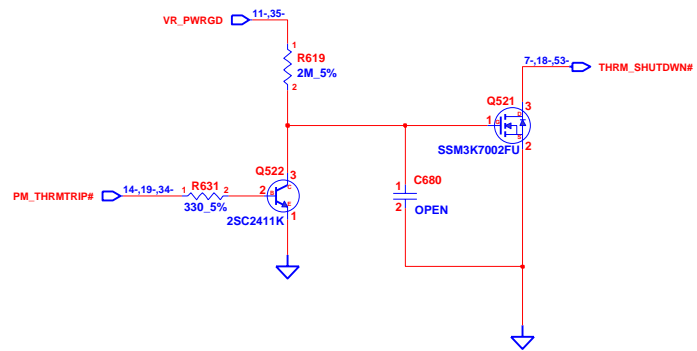
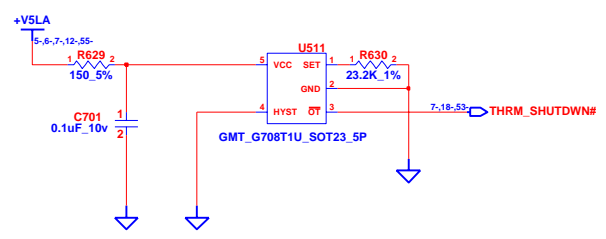
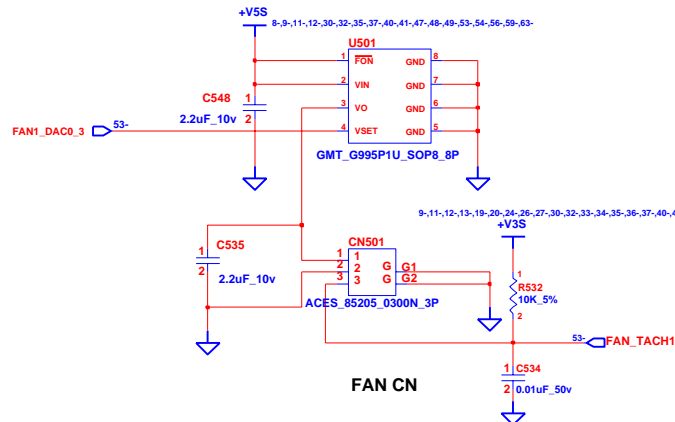

Thermal shoutdown at 89C +/-3C from 60C to 100C
 $RSET=0.0012*T^2 - 0.9308*T+96.147$
 Hysteresis is 30C

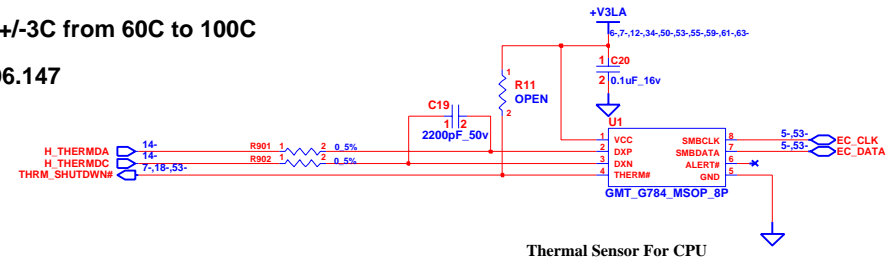

INVENTEC			
TITLE PS10S THERMAL&FAN CONTROLLER			
SIZE A3	CODE CS	DOC. NUMBER Model No	REV X01
CHANGE by IEC951098		29-Sep-2007	
SHEET 18		OF 63	

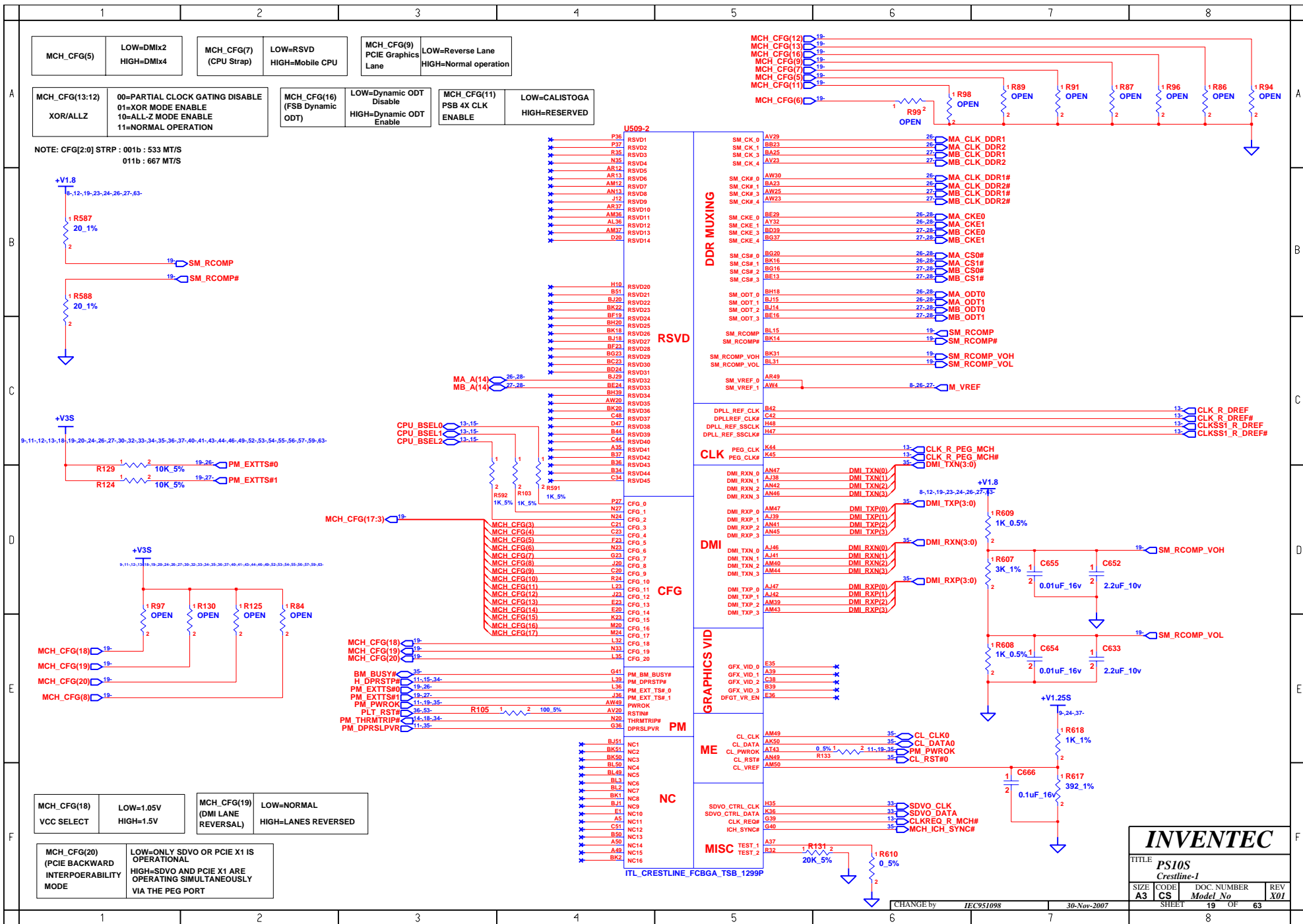

INVENTEC

TITLE
PS10S
Crestline-1

SIZE A3	CODE CS	DOC. NUMBER Model No	REV X01
SHEET 19		OF 63	

CHANGE by IEC951098 30-Nov-2007

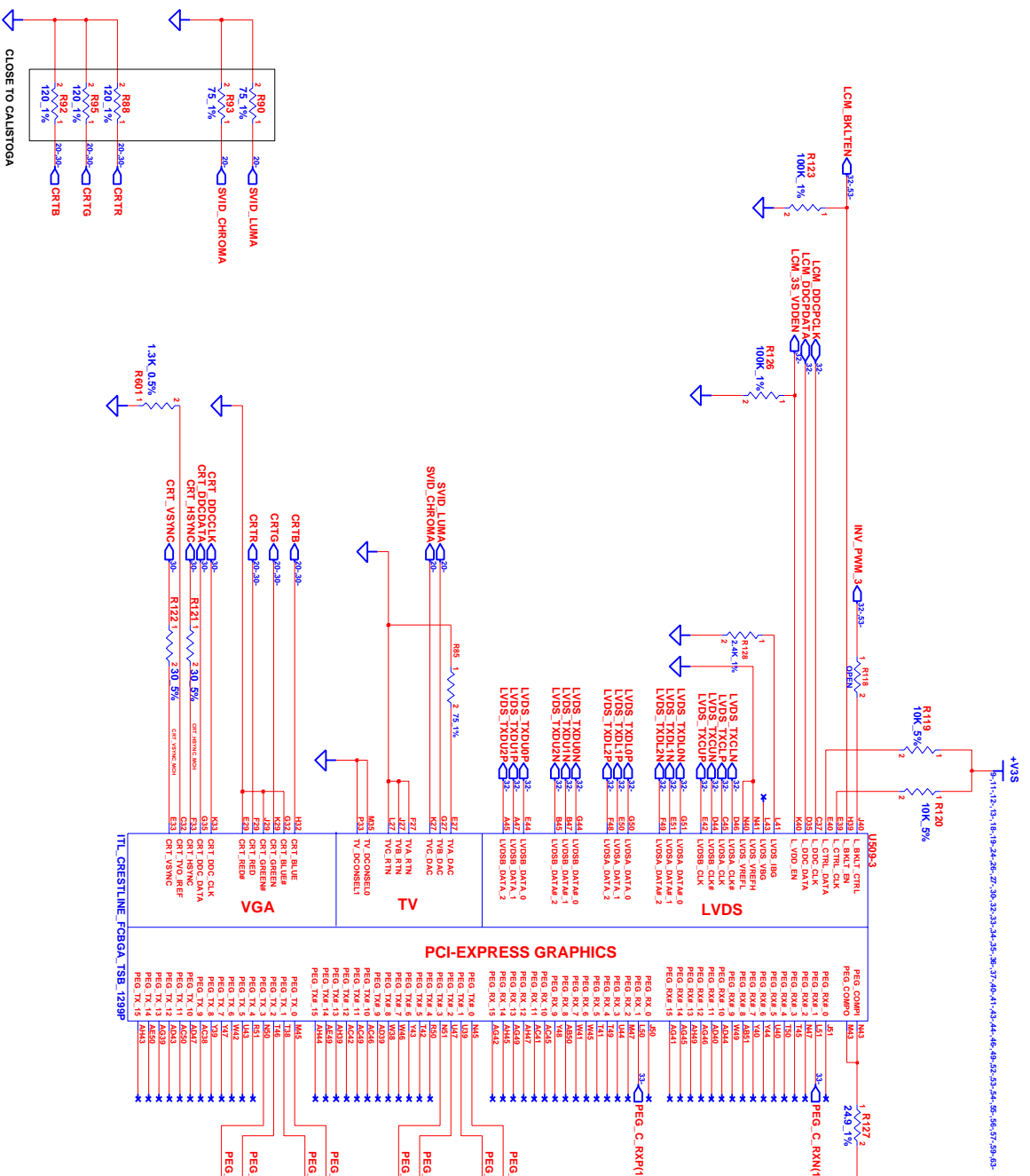

INVENTTEC
 TITLE: *PS105*
 Doc: NUMBER: *Crestline-2*
 SIZE: *A3* CODE: *CS* Model: *NO* REV: *X01*
 SHEET: *20* OF: *63*

CHANGED by: *IE2951008* 7 12-SEP-2007 8

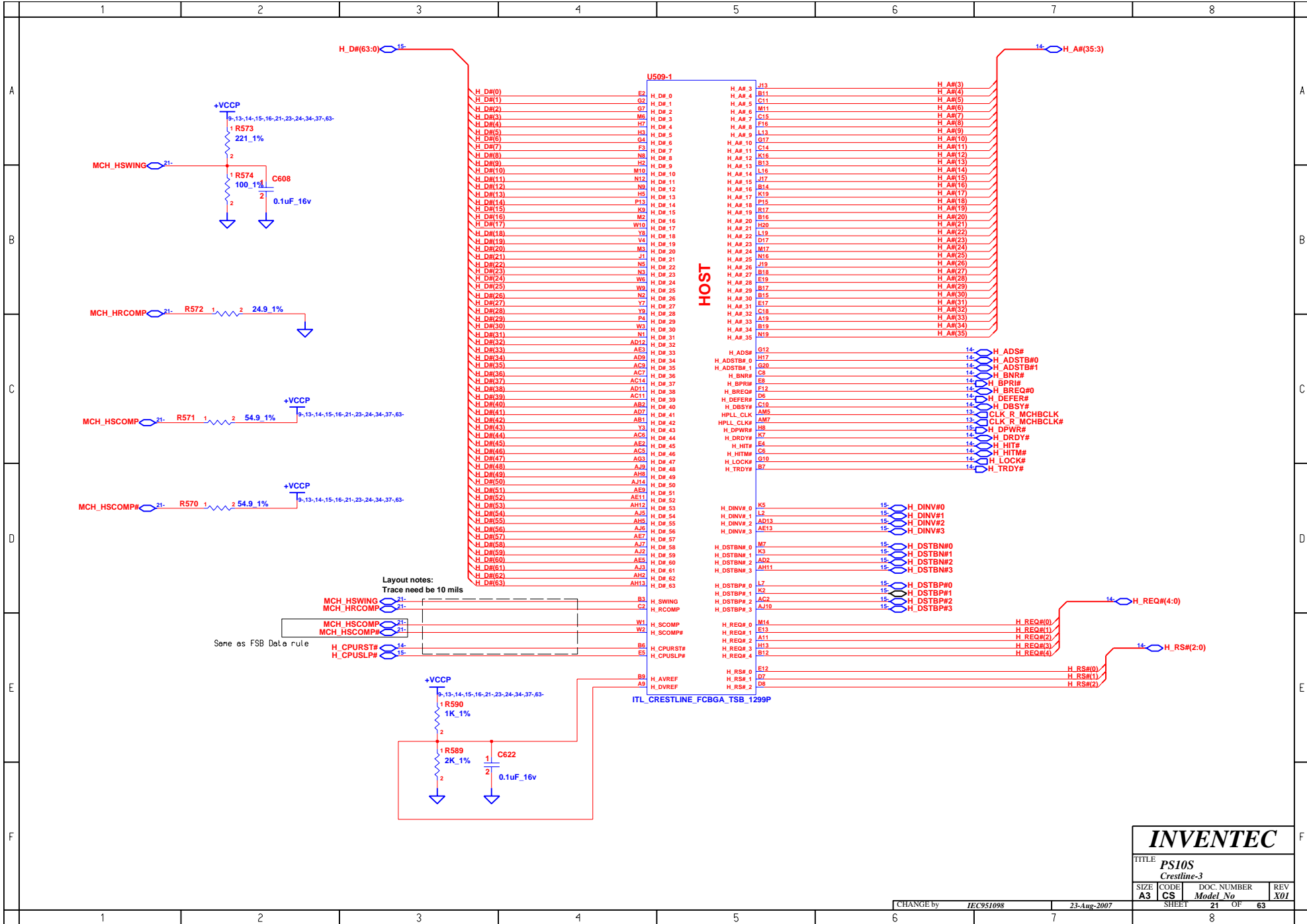

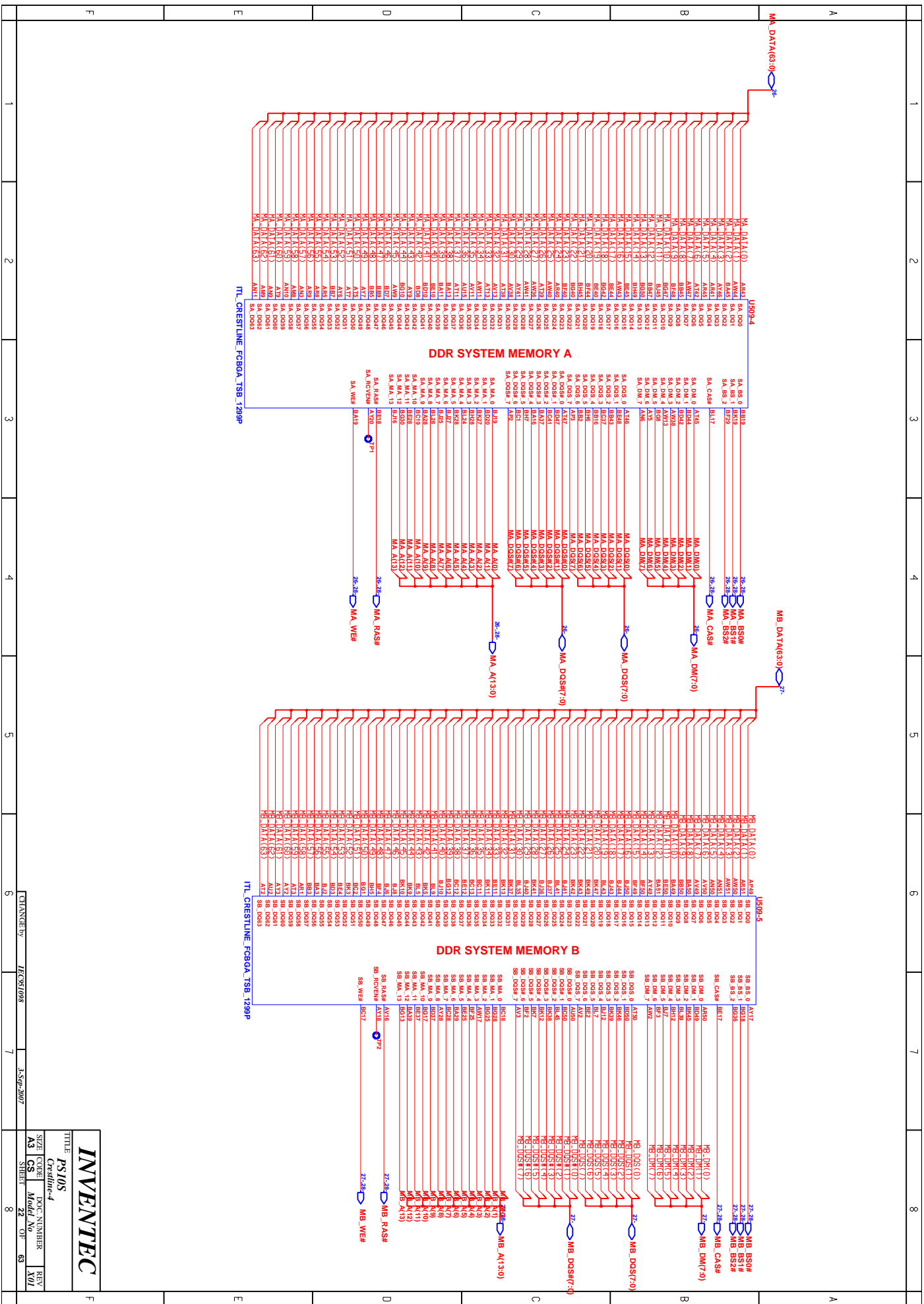

DDR SYSTEM MEMORY A

DDR SYSTEM MEMORY B

CHANGED BY: *litcsg1008*

3-SEP-2007

INVENTTEC			
TITLE: <i>PS10S</i>			
Crestline-4			
SIZE	CODE	DOC:NUMBER	REV
A3	CS	Model No	X01
SHEET	22	OF	63

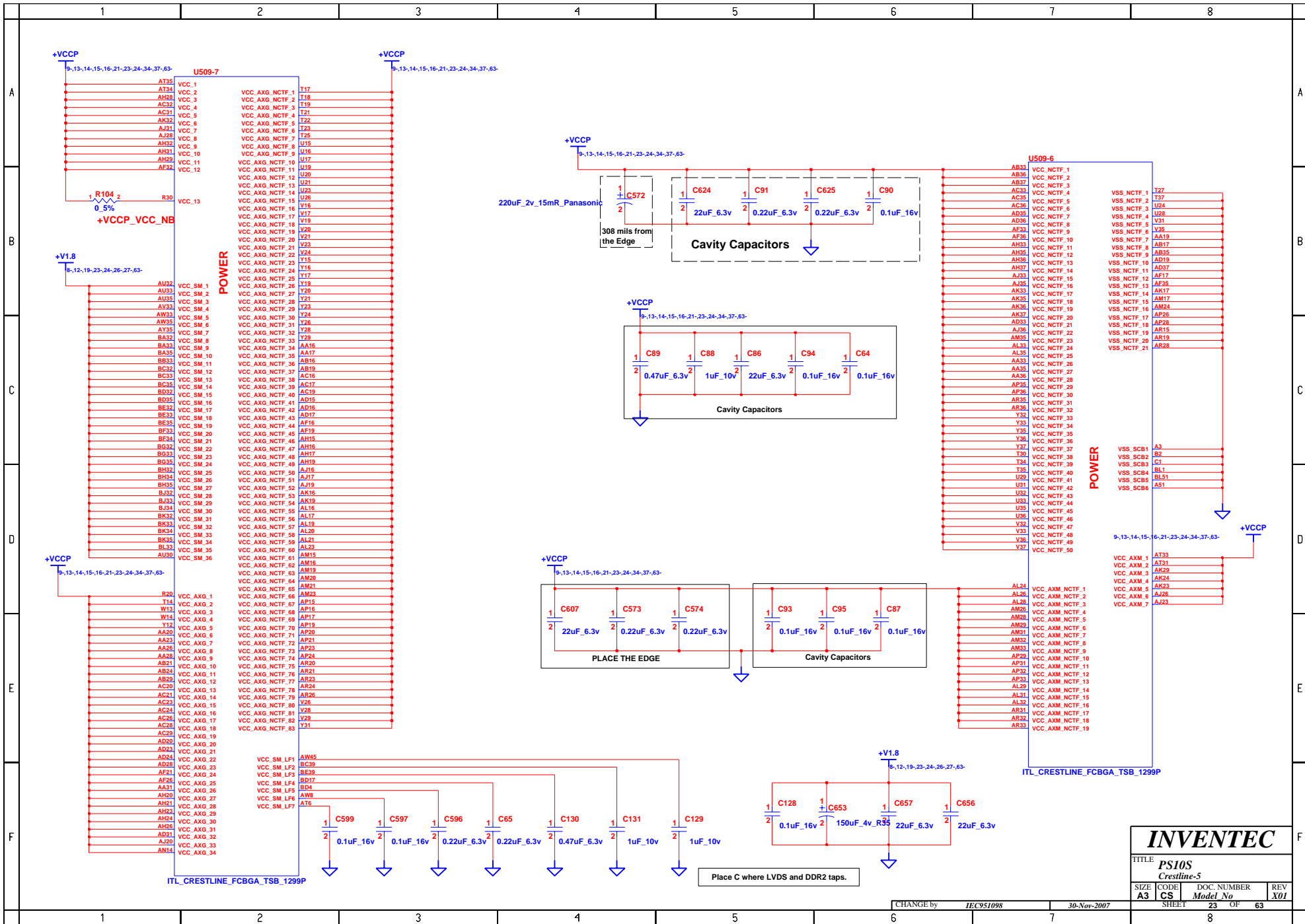

INVENTEC

TITLE: PS10S Crestline-5

SIZE	CODE	DOC. NUMBER	REV
A3	CS	Model No	X01

SHEET 23 OF 63

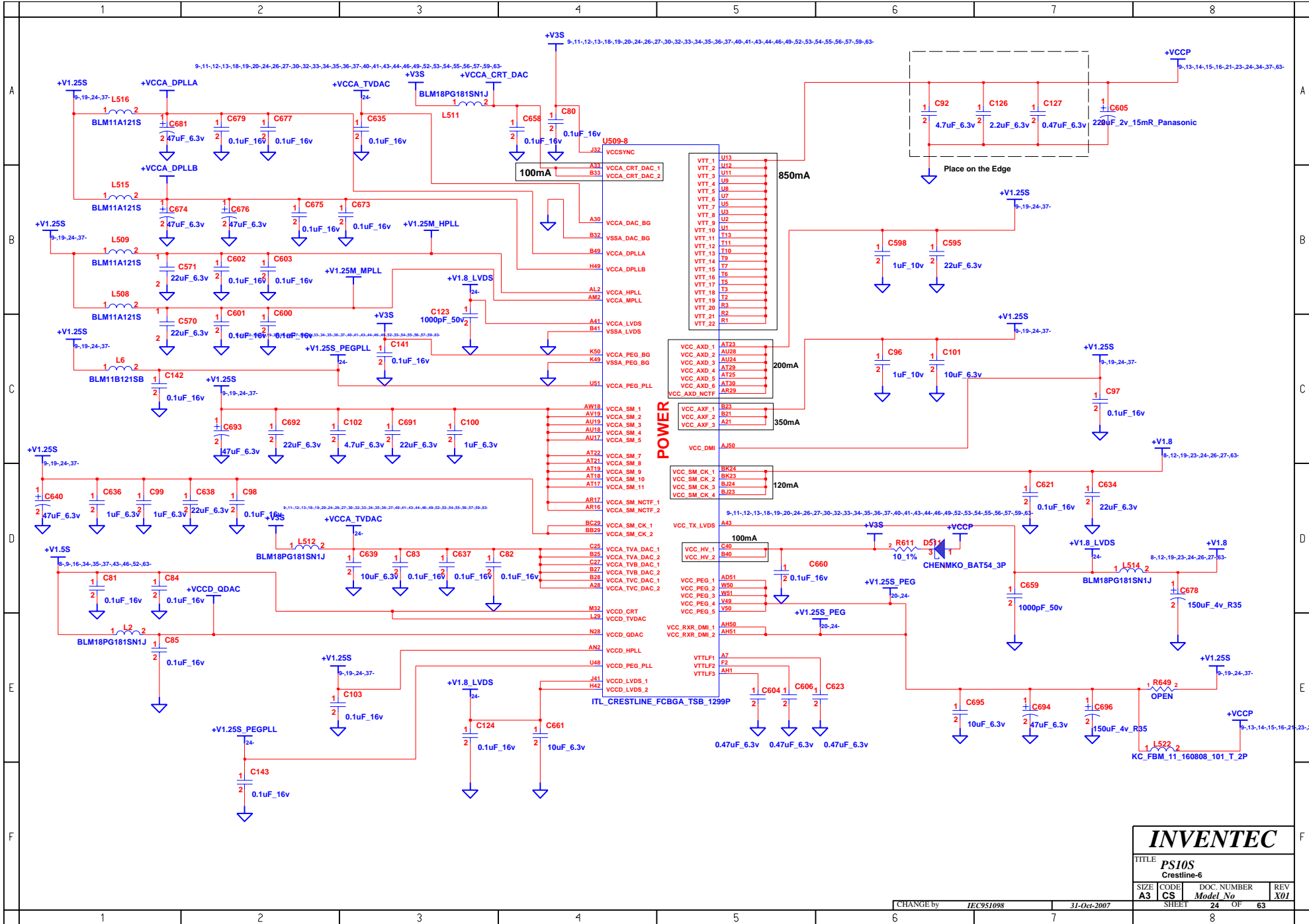

INVENTEC

TITLE PS10S
Crestline-6

SIZE	CODE	DOC. NUMBER	REV
A3	CS	Model No	X01

CHANGE by IEC951098

31-Oct-2007

SHEET 24 OF 63

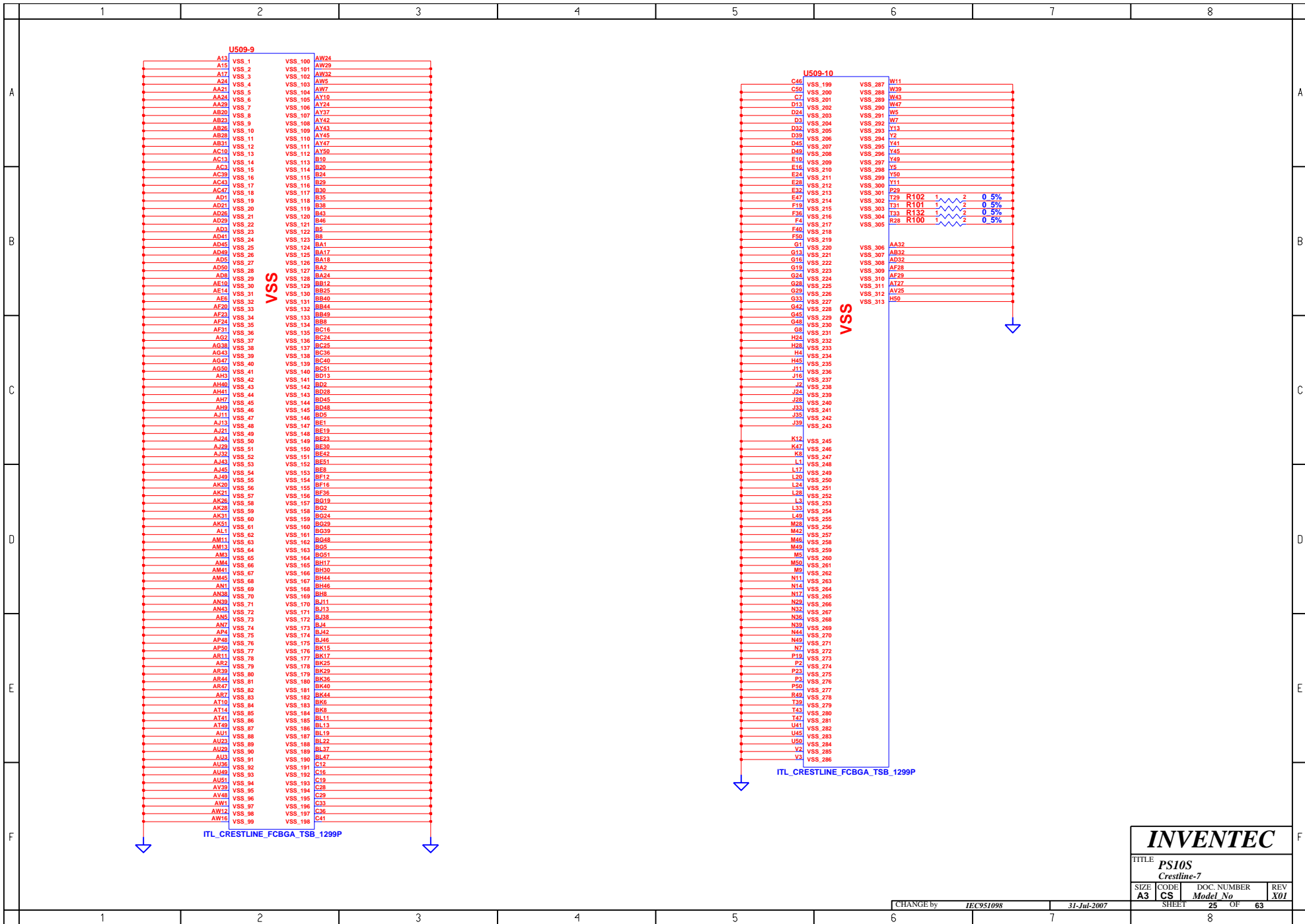

INVENTEC			
TITLE PS10S Crestline-7			
SIZE A3	CODE CS	DOC. NUMBER Model No	REV X01
CHANGE by IEC951098		31-Jul-2007	
SHEET 25		OF 63	

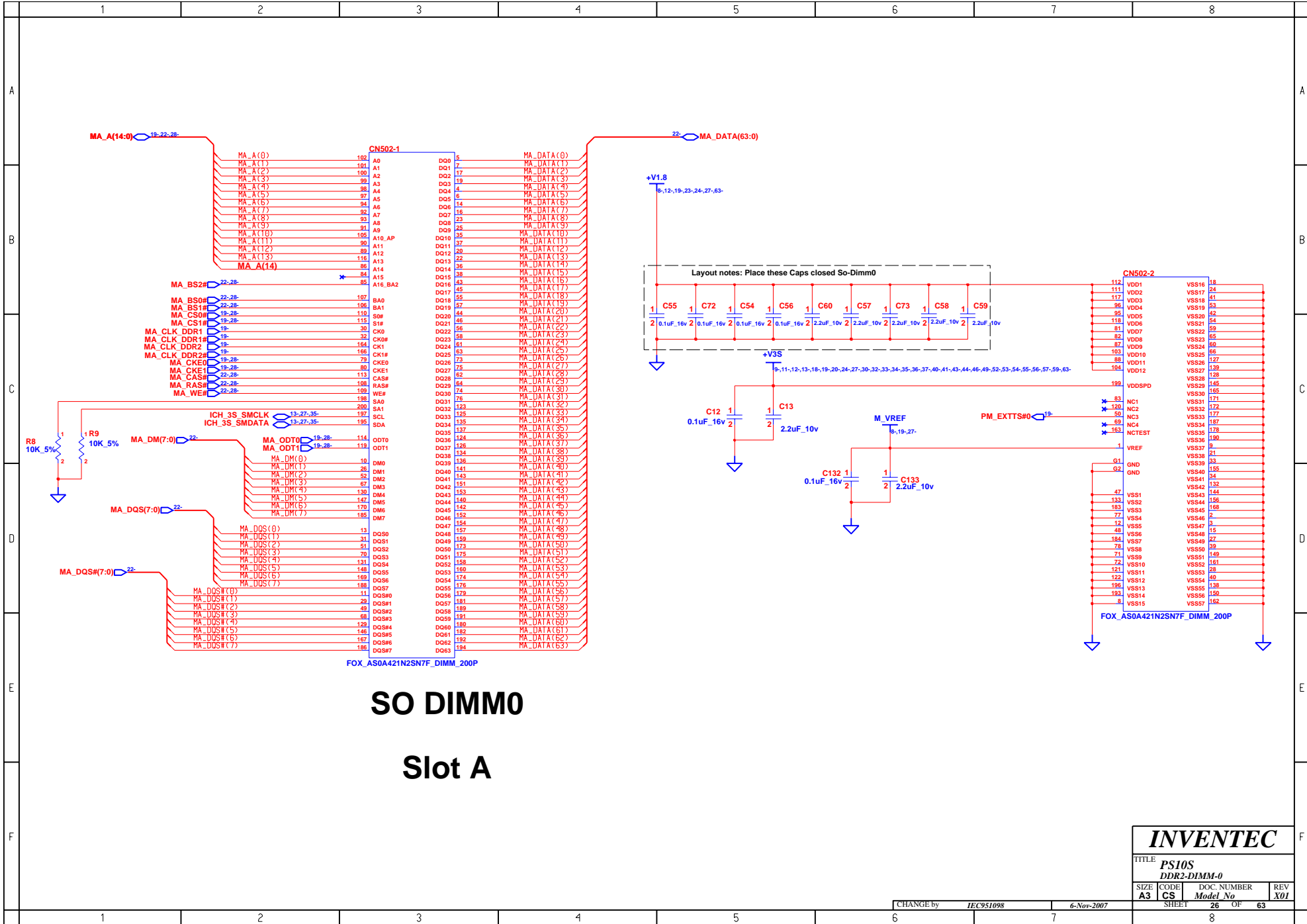

INVENTEC			
TITLE PS10S DDR2-DIMM-0			
SIZE A3	CODE CS	DOC. NUMBER <i>Model No</i>	REV X01
CHANGE by <i>IEC951098</i>		6-Nov-2007	
SHEET 26		OF 63	
1		8	

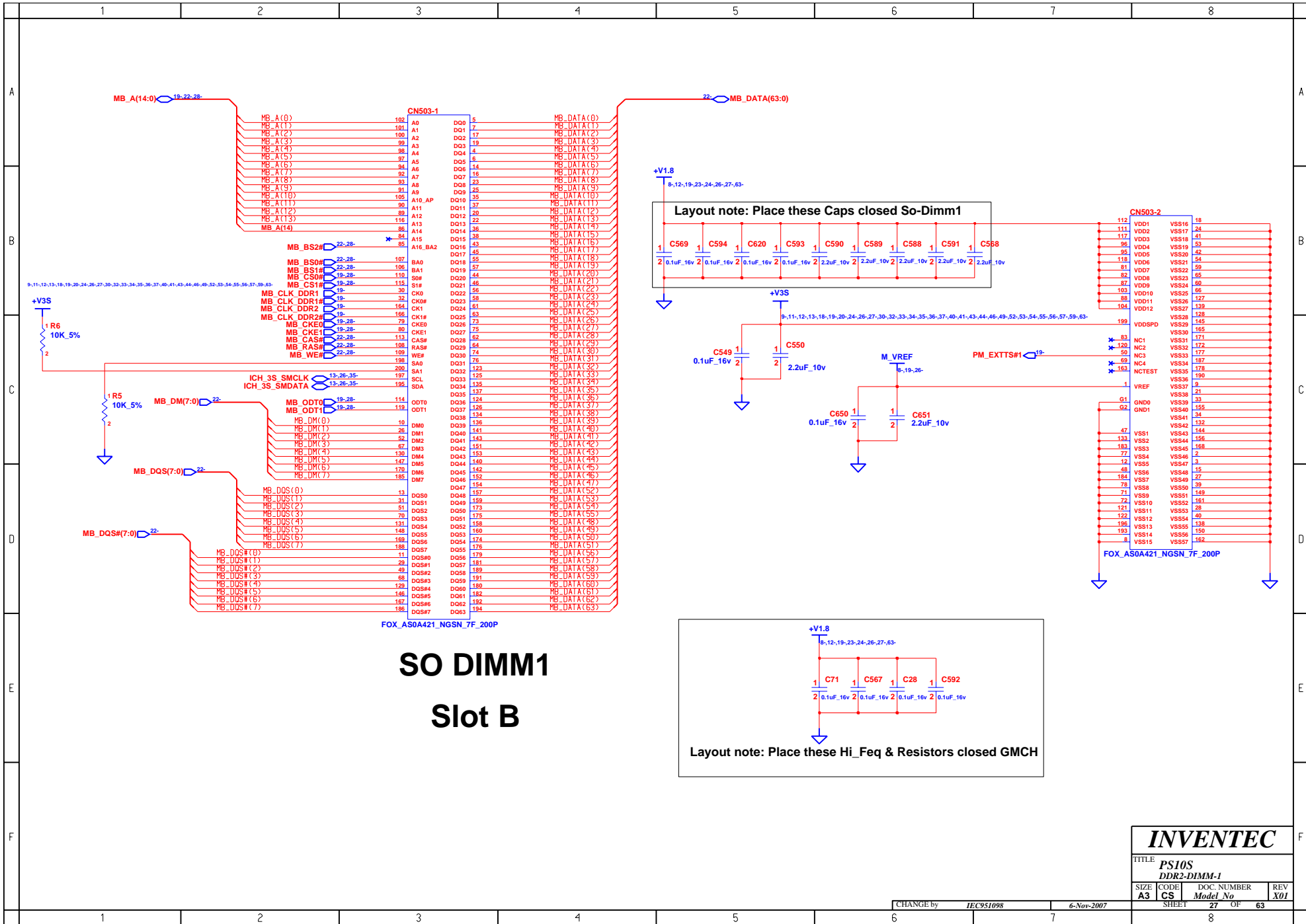

INVENTEC

TITLE PS10S DDR2-DIMM-1			
SIZE A3	CODE CS	DOC. NUMBER Model No	REV X01
CHANGE by IEC951098		6-Nov-2007	
SHEET 27		OF 63	



BLANK

INVENTEC

TITLE			
PS10S			
MXM CONN			
SIZE	CODE	DOC. NUMBER	REV
A3	CS	<i>Model No</i>	X01
SHEET		29	OF 63

CHANGE by *IEC951098* 30-Nov-2007

	1	2	3	4	5	6	7	8	
A									A
B									B
C									C
D									D
E									E
F									F
	1	2	3	4	5	6	7	8	

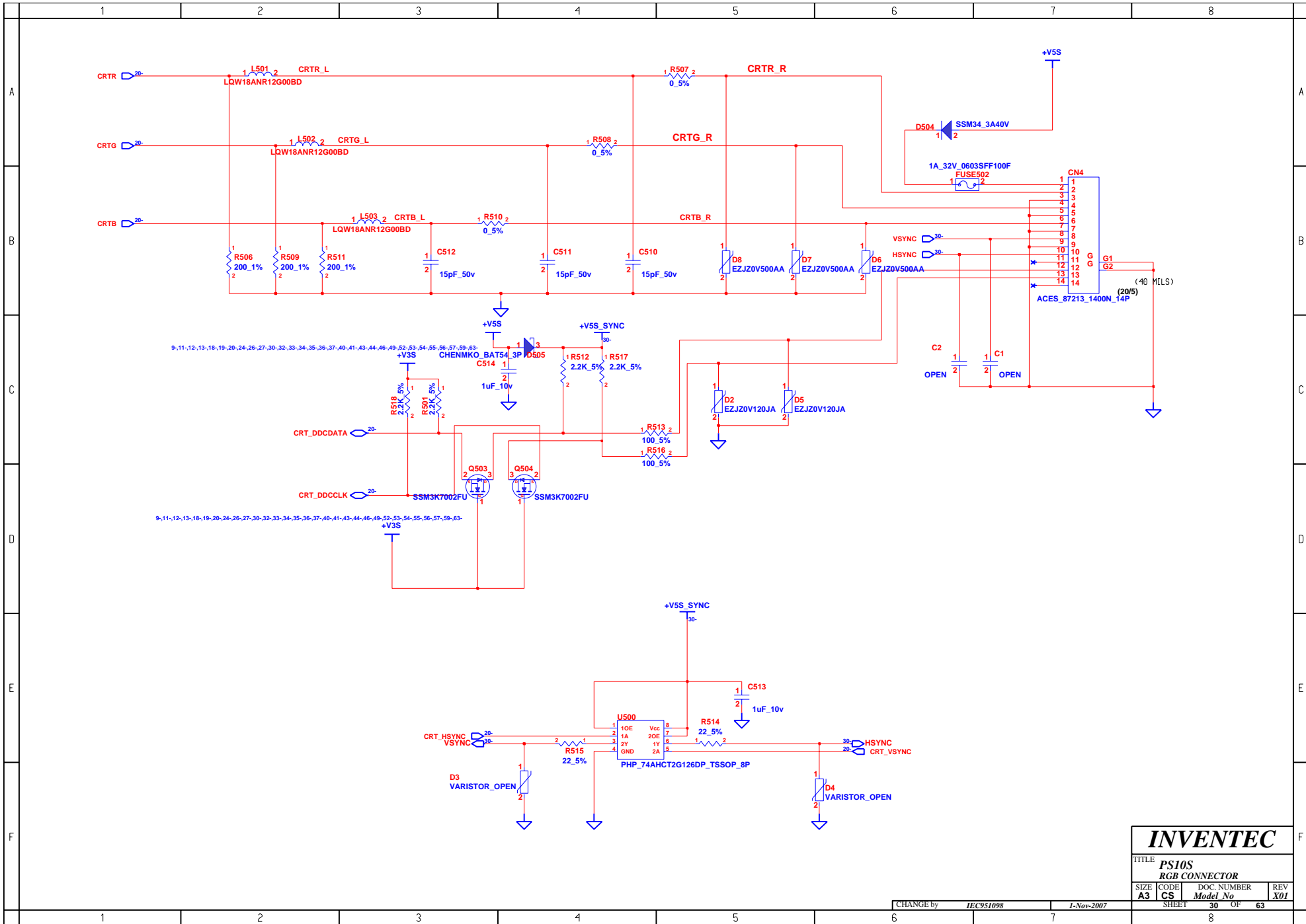

INVENTEC			
TITLE PS10S RGB CONNECTOR			
SIZE A3	CODE CS	DOC. NUMBER Model No	REV X01
CHANGE by IEC951098		J-Nov-2007	
SHEET 30		OF 63	

BLANK

INVENTEC			
TITLE <i>PS10S</i>			
S-Video CONN			
SIZE	CODE	DOC. NUMBER	REV
A3	CS	<i>Model No</i>	X01
CHANGE by <i>IEC951098</i>		30-Nov-2007	
SHEET		31	OF 63

	1	2	3	4	5	6	7	8	
A									A
B									B
C									C
D									D
E									E
F									F
	1	2	3	4	5	6	7	8	

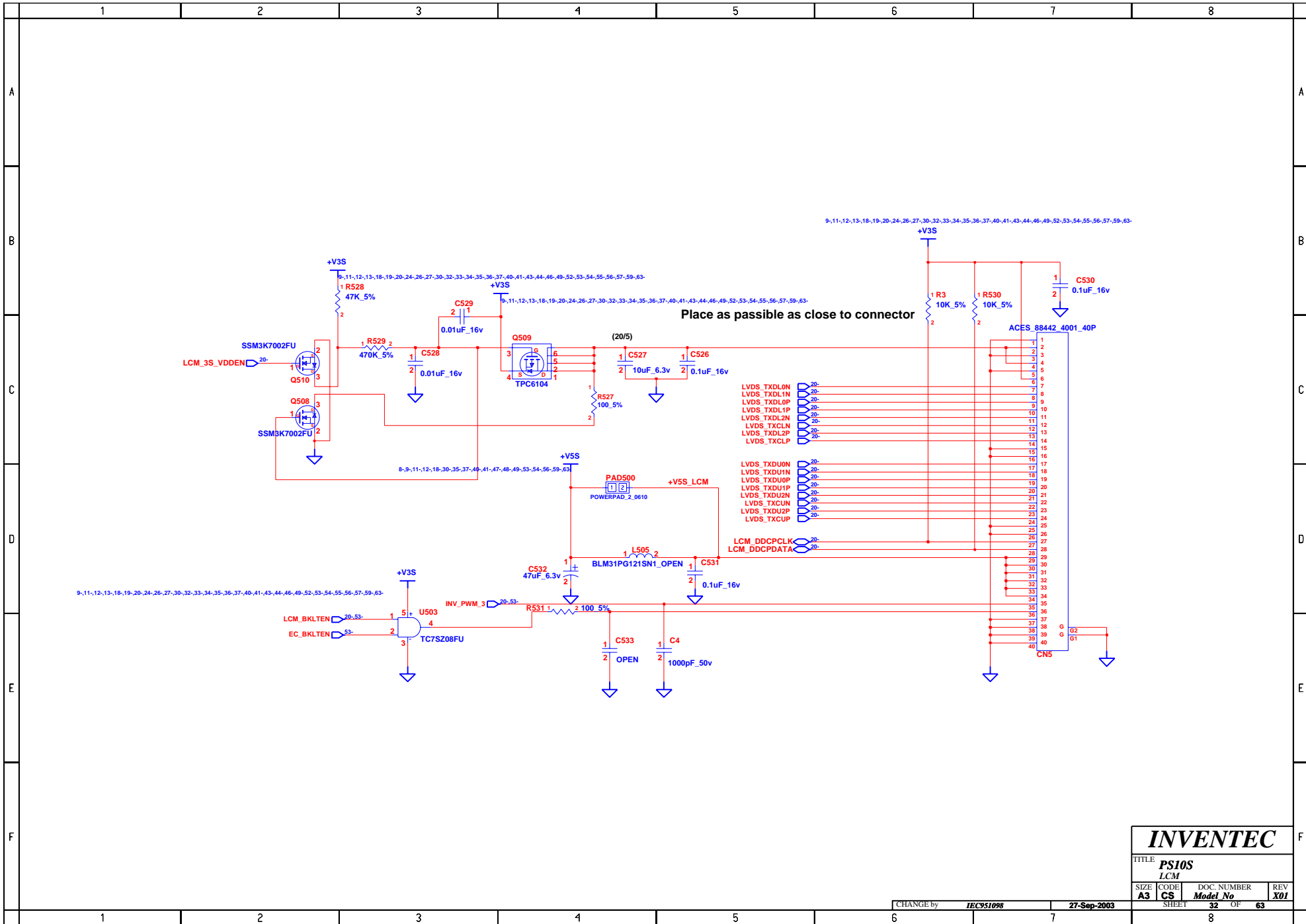

INVENTEC			
TITLE PS10S			
LCM			
SIZE A3	CODE CS	DOC. NUMBER Model No	REV X01
CHANGE by JEC951098		27-Sep-2003	
SHEET		32 OF 63	

HDMI TRANSMITTER

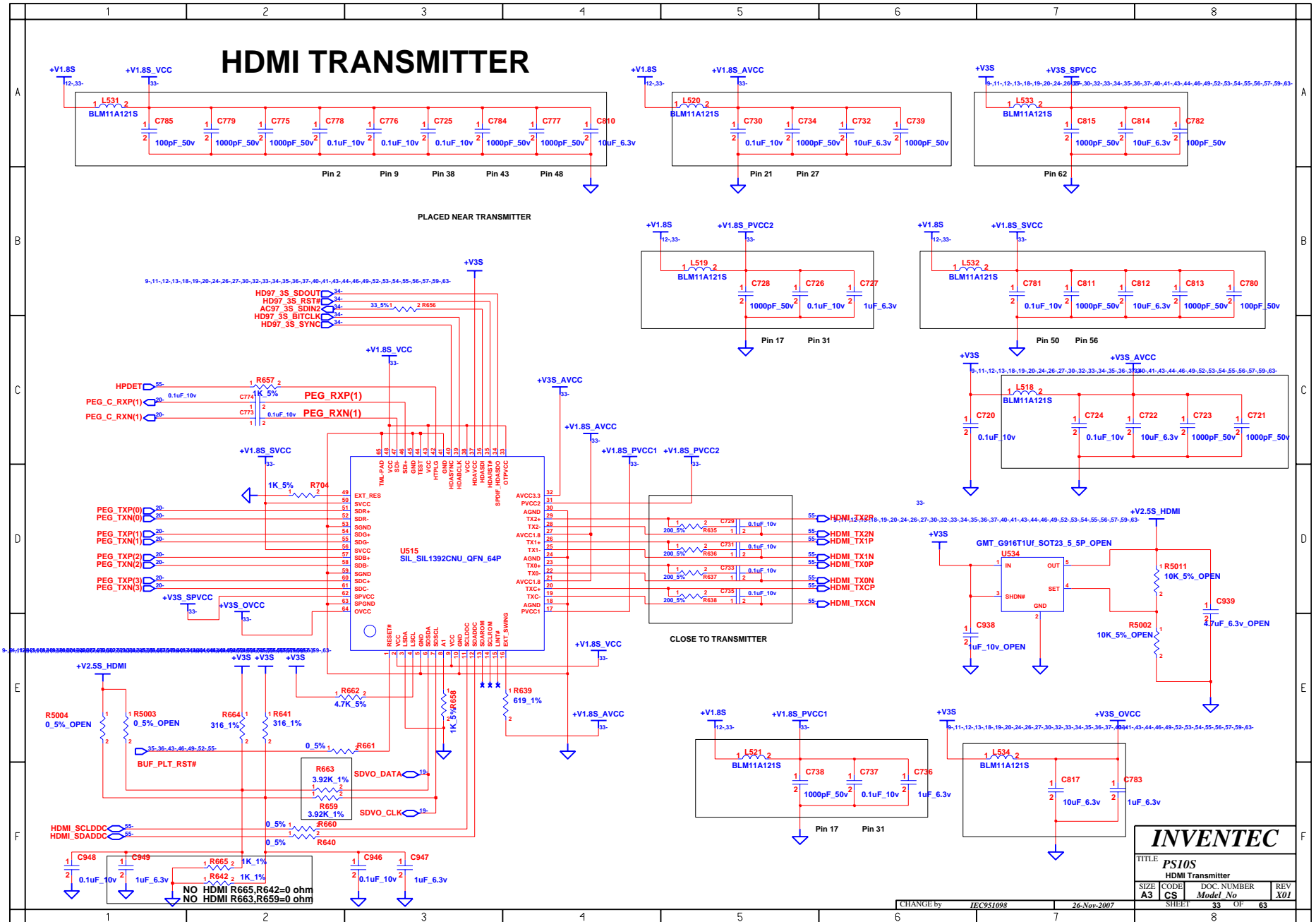

INVENTEC

TITLE				PS10S
HDMI Transmitter				
SIZE	CODE	DOC. NUMBER	REV	
A3	CS	Model No	X01	

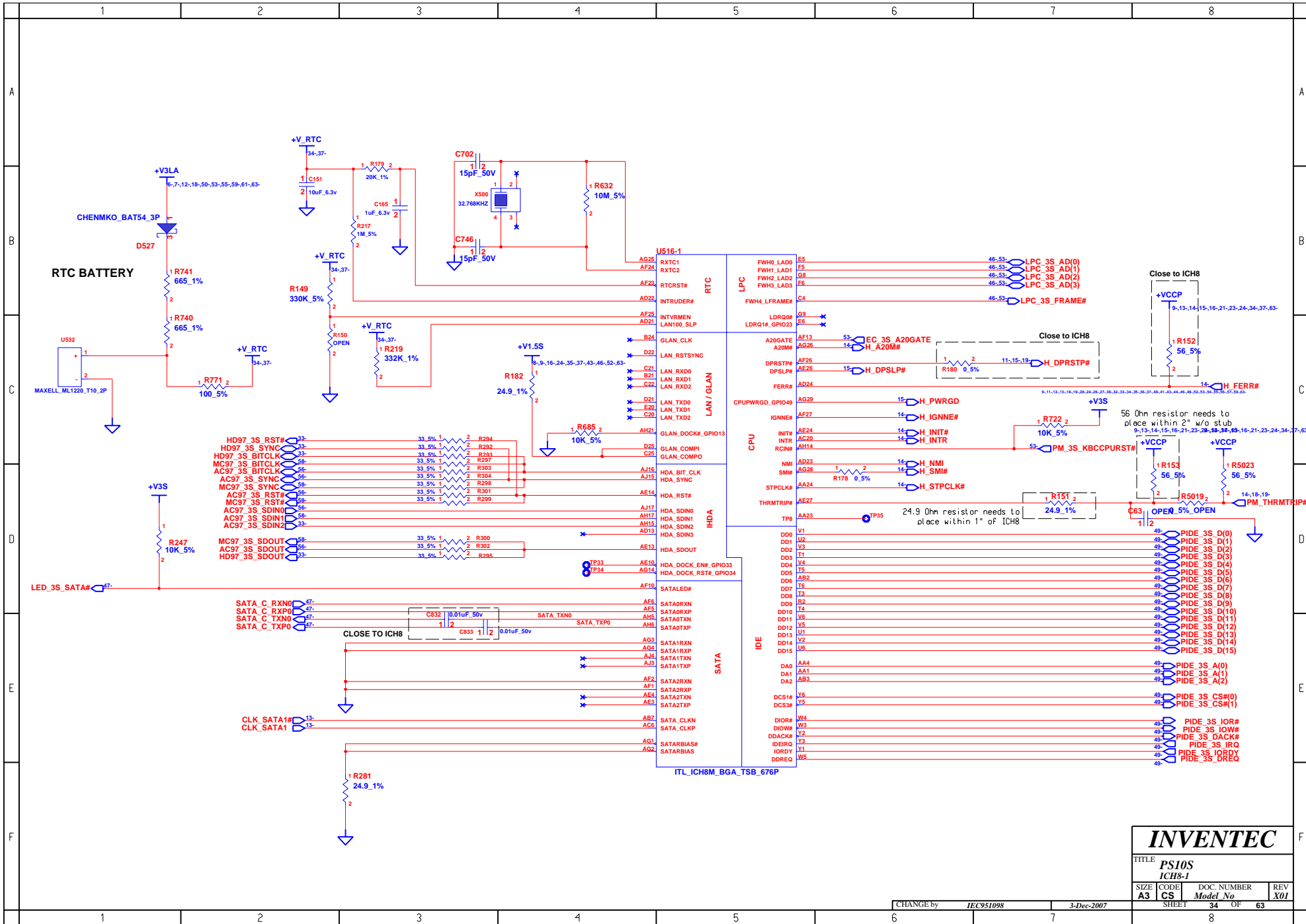

INVENTEC			
TITLE PS10S ICH8-1			
SIZE A3	CODE CS	DOC. NUMBER Model No	REV X01
CHANGE by IEC951098		3-Dec-2007	
SHEET 34		OF 63	

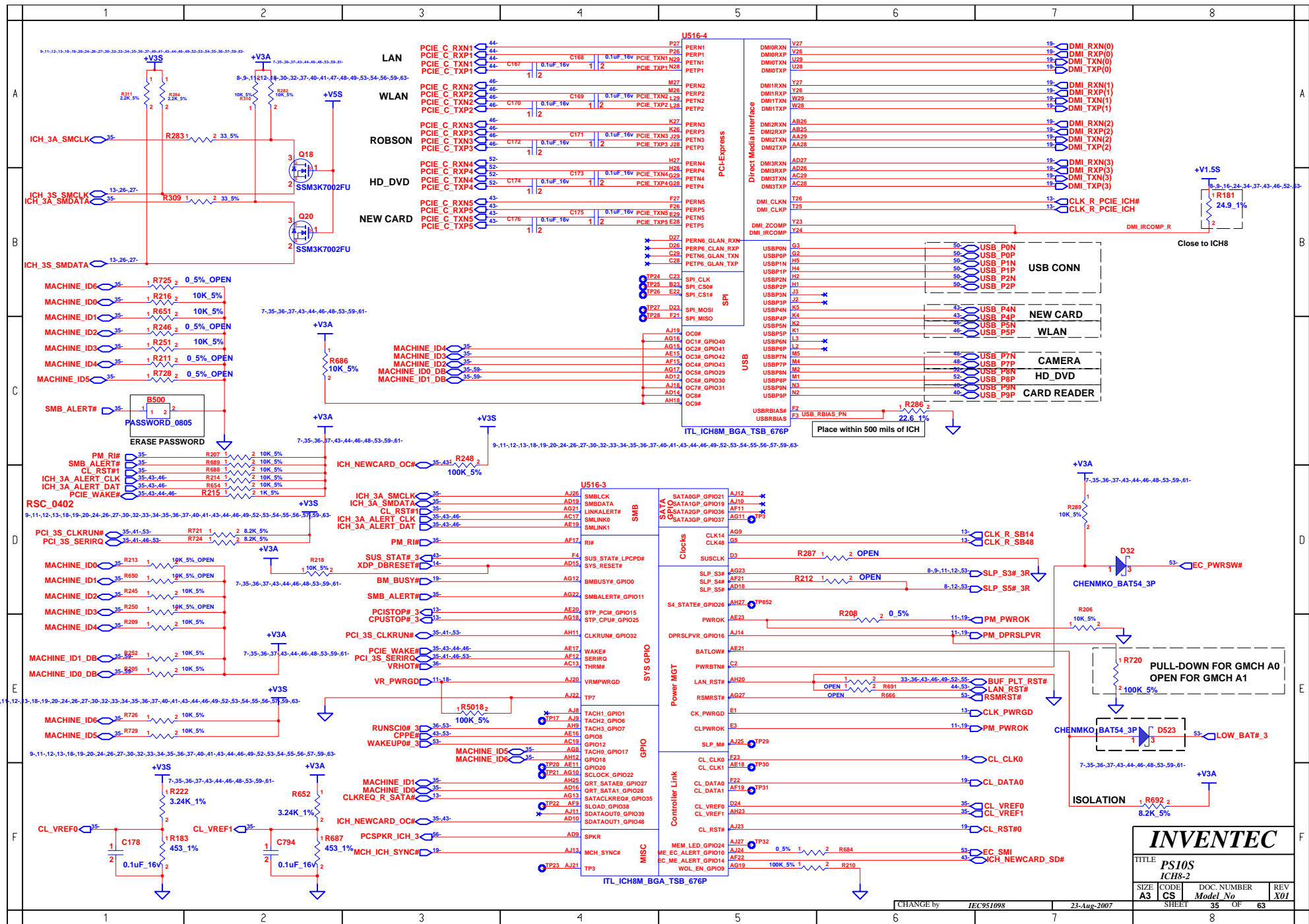

INVENTEC			
TITLE PS10S ICH8-2			
SIZE A3	CODE CS	DOC. NUMBER <i>Model No</i>	REV X01
SHEET 35		OF 63	

CHANGE by IEC951098 23-Aug-2007

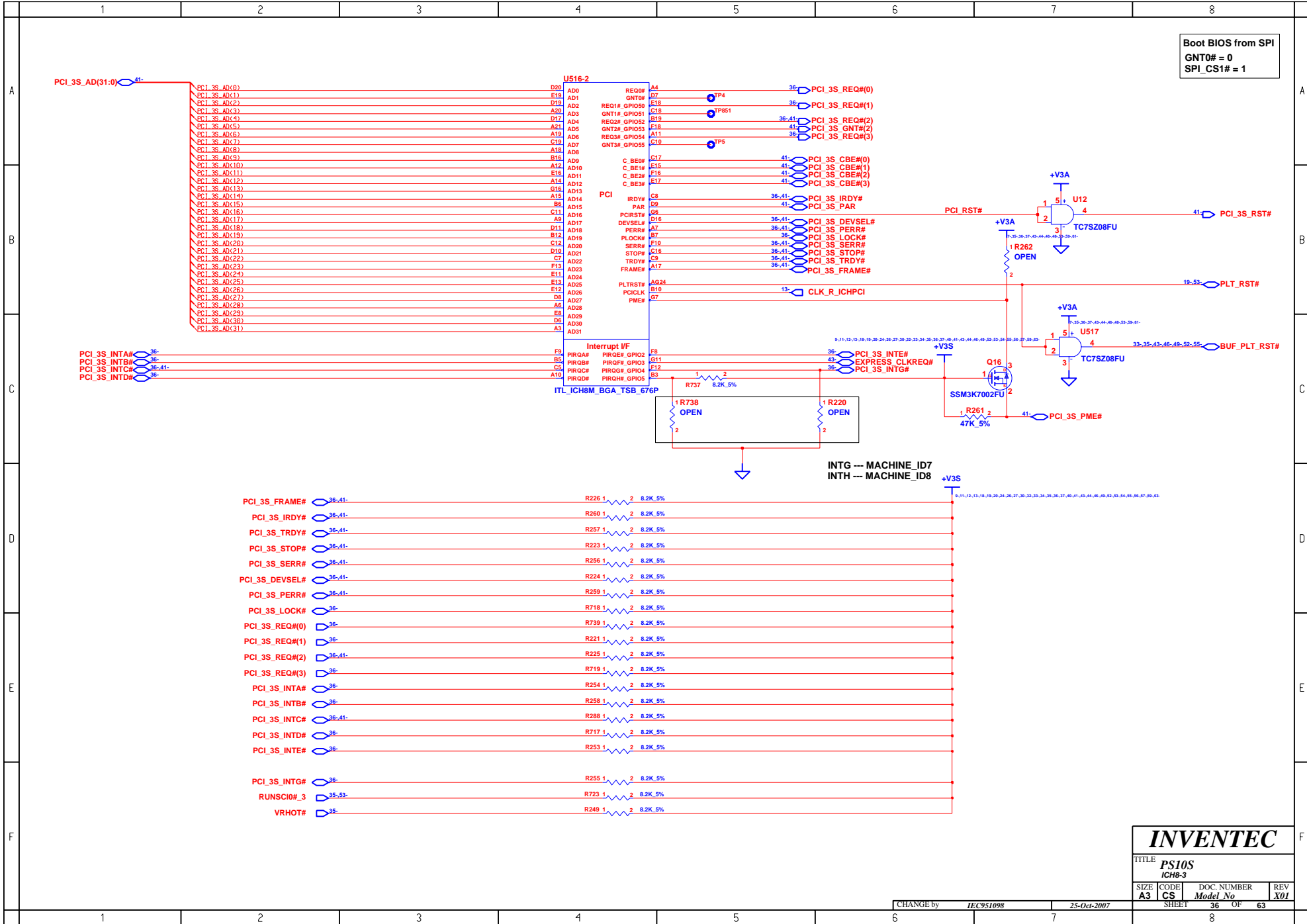

INVENTEC			
TITLE PS10S ICH8-3			
SIZE A3	CODE CS	DOC. NUMBER Model No	REV X01
CHANGE by IEC951098		25-Oct-2007	
SHEET 36		OF 63	

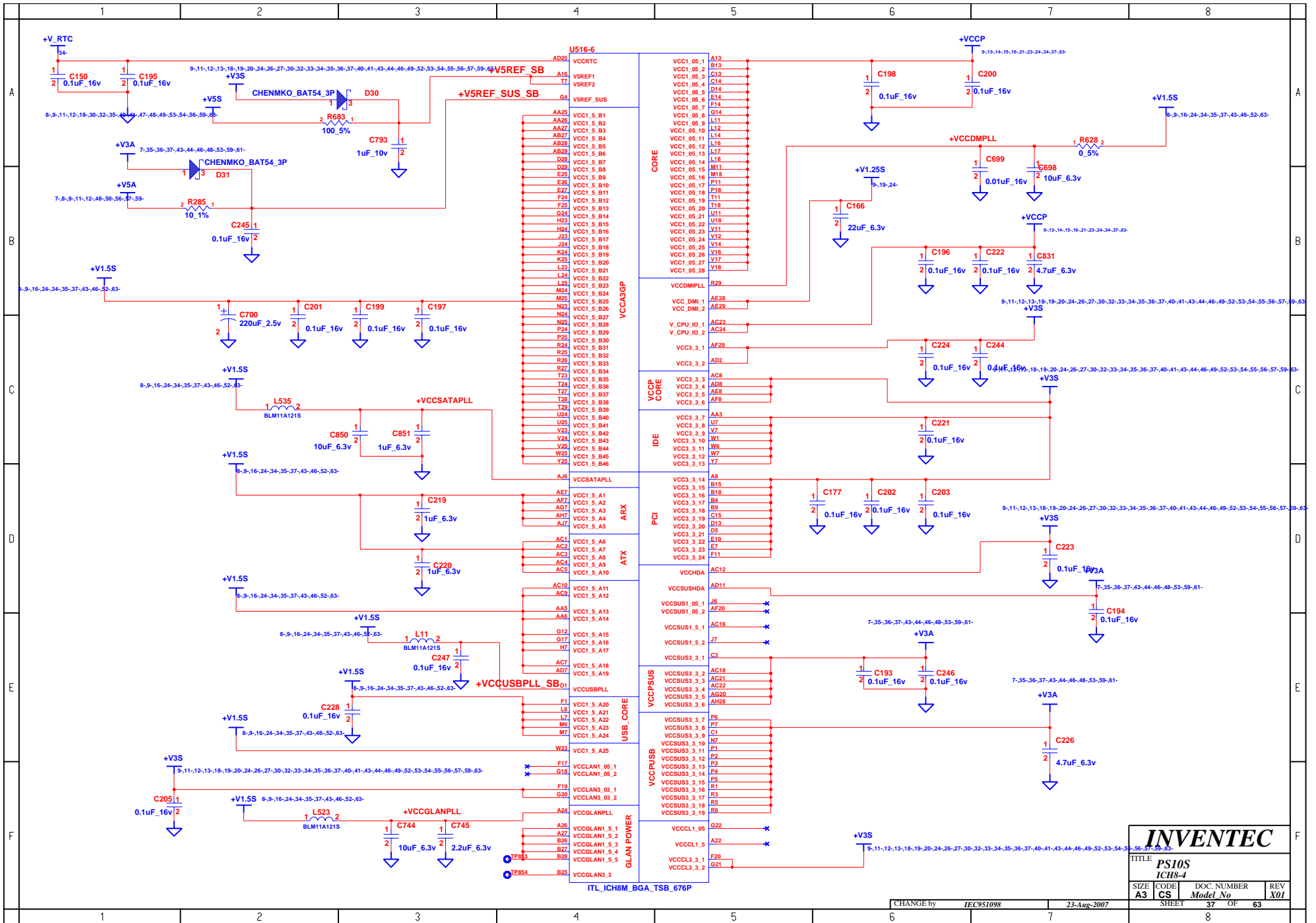

INVENTEC			
TITLE PS10S ICH8-4			
SIZE A3	CODE CS	DOC. NUMBER Model No	REV X01
CHANGE by IEC951098		23-Aug-2007	
SHEET 37		OF 63	

	1	2	3	4	5	6	7	8
A								
B								
C								
D								
E								
F								

U516-5

A23	VSS001	VSS009	K7
A5	VSS002	VSS100	L1
AA2	VSS003	VSS101	L13
AAZ	VSS004	VSS102	L15
AAZ	VSS005	VSS103	L26
AB1	VSS006	VSS104	L27
AB24	VSS007	VSS105	L4
AC11	VSS008	VSS106	L5
AC14	VSS009	VSS107	M12
AC25	VSS010	VSS108	M13
AC26	VSS011	VSS109	M14
AC27	VSS012	VSS110	M15
AD17	VSS013	VSS111	M16
AD20	VSS014	VSS112	M17
AD28	VSS015	VSS113	M23
AD29	VSS016	VSS114	M28
AD3	VSS017	VSS115	M29
AD4	VSS018	VSS116	M3
AD6	VSS019	VSS117	N1
AE1	VSS020	VSS118	N11
AE12	VSS021	VSS119	N12
AE2	VSS022	VSS120	N13
AE22	VSS023	VSS121	N14
AD1	VSS024	VSS122	N15
AE25	VSS025	VSS103	N16
AE5	VSS026	VSS124	N17
AE6	VSS027	VSS125	N18
AE9	VSS028	VSS126	N26
AF14	VSS029	VSS127	N27
AF16	VSS030	VSS128	N4
AF18	VSS031	VSS129	N5
AF3	VSS032	VSS130	N6
AF4	VSS033	VSS131	P12
AG5	VSS034	VSS132	P13
AG6	VSS035	VSS133	P14
AH10	VSS036	VSS134	P15
AH13	VSS037	VSS135	P16
AH16	VSS038	VSS136	P17
AH19	VSS039	VSS137	P23
AH2	VSS040	VSS138	P28
AF28	VSS041	VSS139	P29
AH22	VSS042	VSS140	R11
AH24	VSS043	VSS141	R12
AH26	VSS044	VSS142	R13
AH3	VSS045	VSS143	R14
AH4	VSS046	VSS144	R15
AH8	VSS047	VSS145	R16
AJ5	VSS048	VSS146	R17
B11	VSS049	VSS147	R18
B14	VSS050	VSS148	R28
B17	VSS051	VSS149	R4
B2	VSS052	VSS150	T12
B20	VSS053	VSS151	T13
B22	VSS054	VSS152	T14
BB	VSS055	VSS153	T15
C24	VSS056	VSS154	T16
C26	VSS057	VSS155	T17
C27	VSS058	VSS156	T2
C6	VSS059	VSS157	U12
D12	VSS060	VSS158	U13
D15	VSS061	VSS159	U14
D18	VSS062	VSS160	U15
D2	VSS063	VSS161	U16
D4	VSS064	VSS162	U17
E21	VSS065	VSS163	U23
E24	VSS066	VSS164	U26
E4	VSS067	VSS165	U27
E9	VSS068	VSS166	U3
F16	VSS069	VSS167	U8
E23	VSS070	VSS168	V13
F28	VSS071	VSS169	V15
F29	VSS072	VSS170	V28
F7	VSS073	VSS171	V29
G1	VSS074	VSS172	W2
E2	VSS075	VSS173	W26
G10	VSS076	VSS174	W27
G13	VSS077	VSS175	V28
G19	VSS078	VSS176	V29
G23	VSS079	VSS177	Y4
G25	VSS080	VSS178	AB4
G26	VSS081	VSS179	AB33
G27	VSS082	VSS180	AB5
H25	VSS083	VSS181	AB6
H28	VSS084	VSS182	AD5
H29	VSS085	VSS183	U4
H3	VSS086	VSS184	W24
H6	VSS087	VSS NCTF. 01	A1
J1	VSS088	VSS NCTF. 02	A2
J6	VSS089	VSS NCTF. 03	A28
J26	VSS090	VSS NCTF. 04	A29
J27	VSS091	VSS NCTF. 05	AH1
J6	VSS092	VSS NCTF. 06	AH29
J5	VSS093	VSS NCTF. 07	AJ1
K23	VSS094	VSS NCTF. 08	AJ2
K28	VSS095	VSS NCTF. 09	AJ28
K28	VSS096	VSS NCTF. 010	AJ29
K3	VSS097	VSS NCTF. 011	B1
K6	VSS098	VSS NCTF. 012	B29

ITL_ICH8M_BGA_TSB_676P

INVENTEC

TITLE **PS10S**
ICH8-5

SIZE	CODE	DOC. NUMBER	REV
A3	CS	<i>Model No</i>	X01

SHEET 38 OF 63

	1	2	3	4	5	6	7	8
--	---	---	---	---	---	---	---	---

BLANK

INVENTEC

TITLE
PS10S

SIZE A3	CODE CS	DOC. NUMBER <i>Model No</i>	REV X01
-------------------	-------------------	--------------------------------	-------------------

CHANGE by *IEC951098* 30-Nov-2007

SHEET 39 OF 63

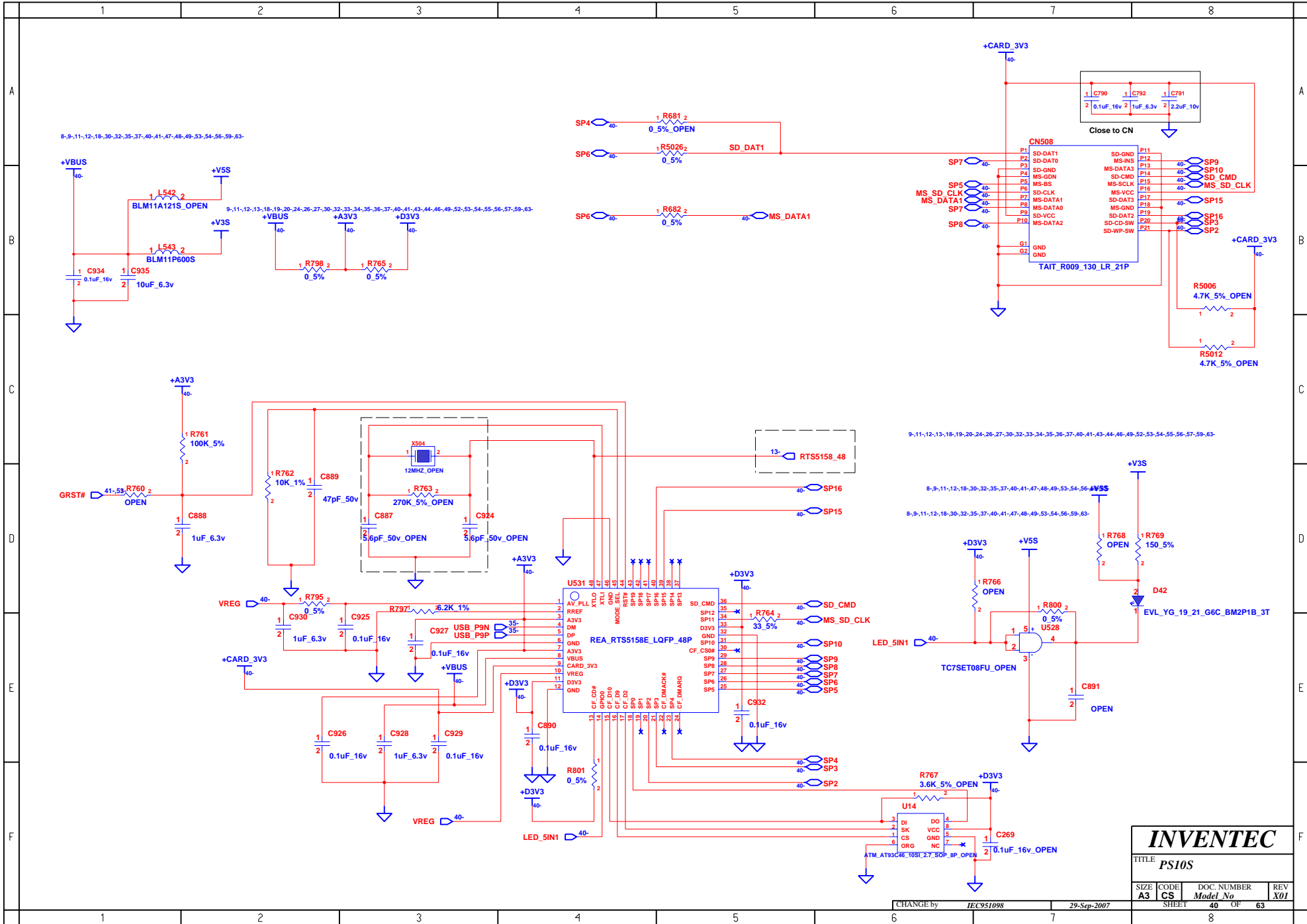

INVENTEC			
TITLE PS10S			
SIZE A3	CODE CS	DOC. NUMBER <i>Model No</i>	REV X01
CHANGE by <i>IEC951098</i>		29-Sep-2007	
SHEET 40		OF 63	

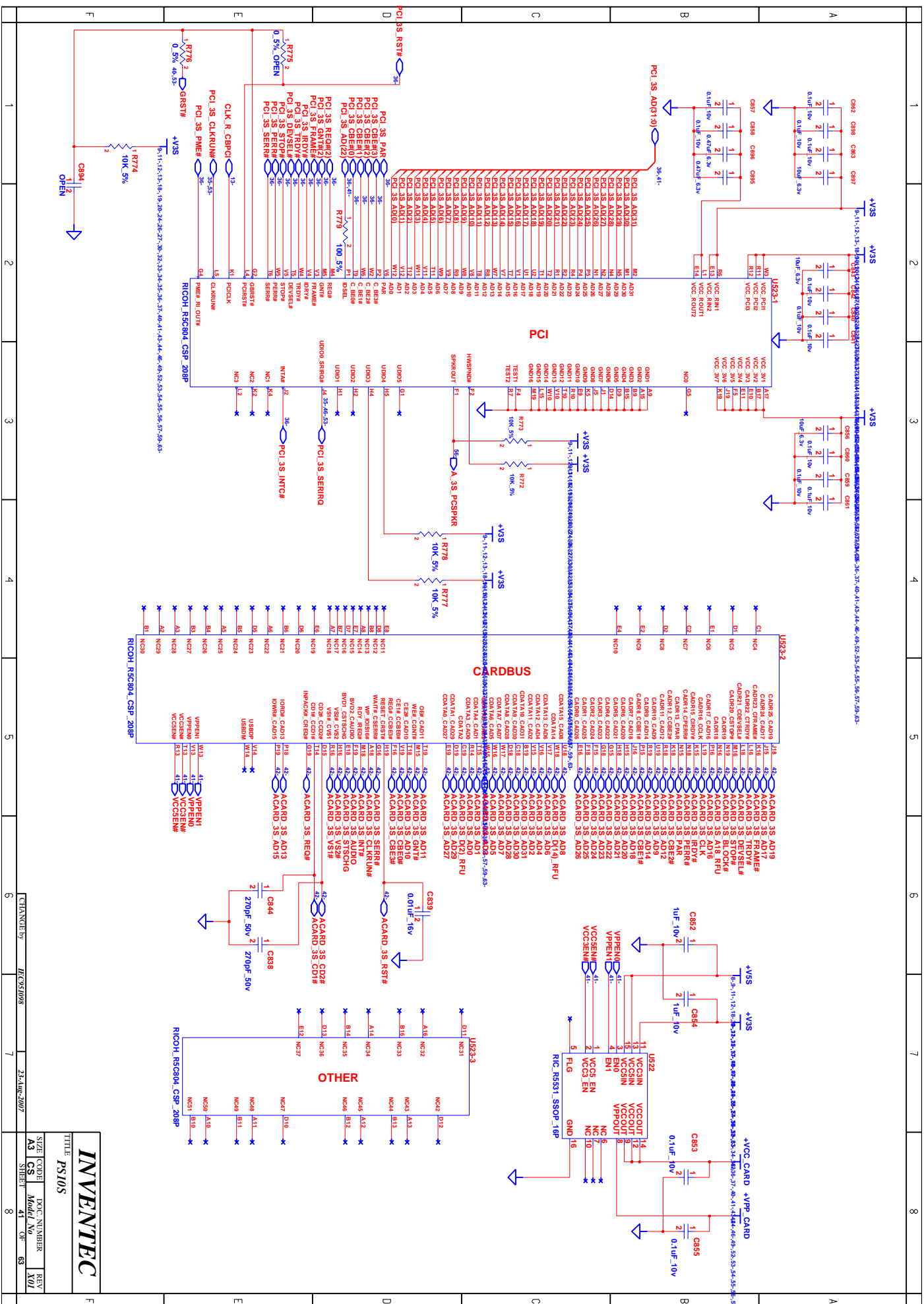

INVENTEC

PS10S

SIZE	CODE	DOC NUMBER	REV
A3	CS	Model No	3/01
SIZE	CODE	DOC NUMBER	REV
A3	CS	Model No	3/01

CHANGE BY: JES/2008 21-10-2007

41

63

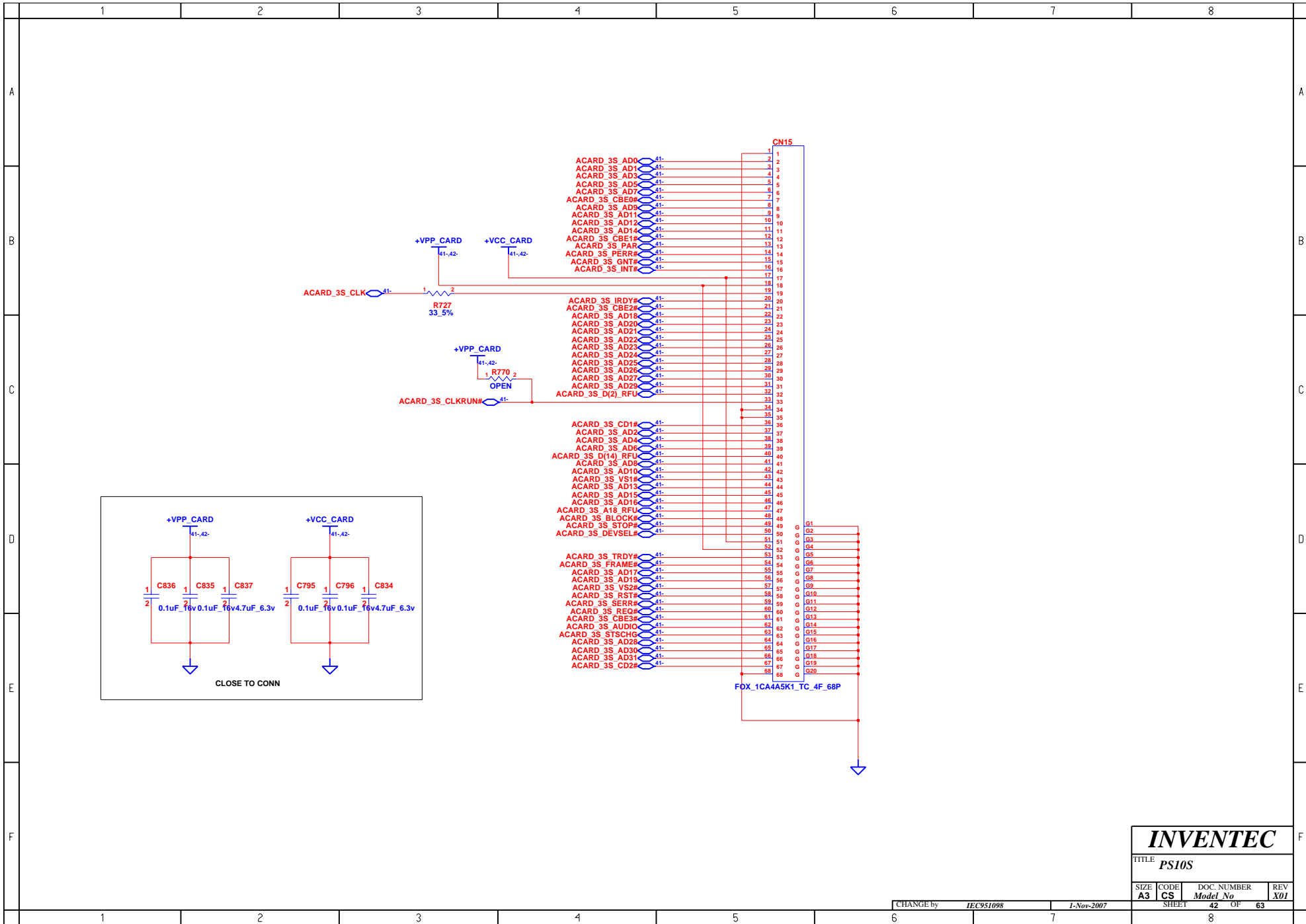

INVENTEC

TITLE
PS10S

SIZE	CODE	DOC. NUMBER	REV
A3	CS	Model No	X01

CHANGE by IEC951098 1-Nov-2007

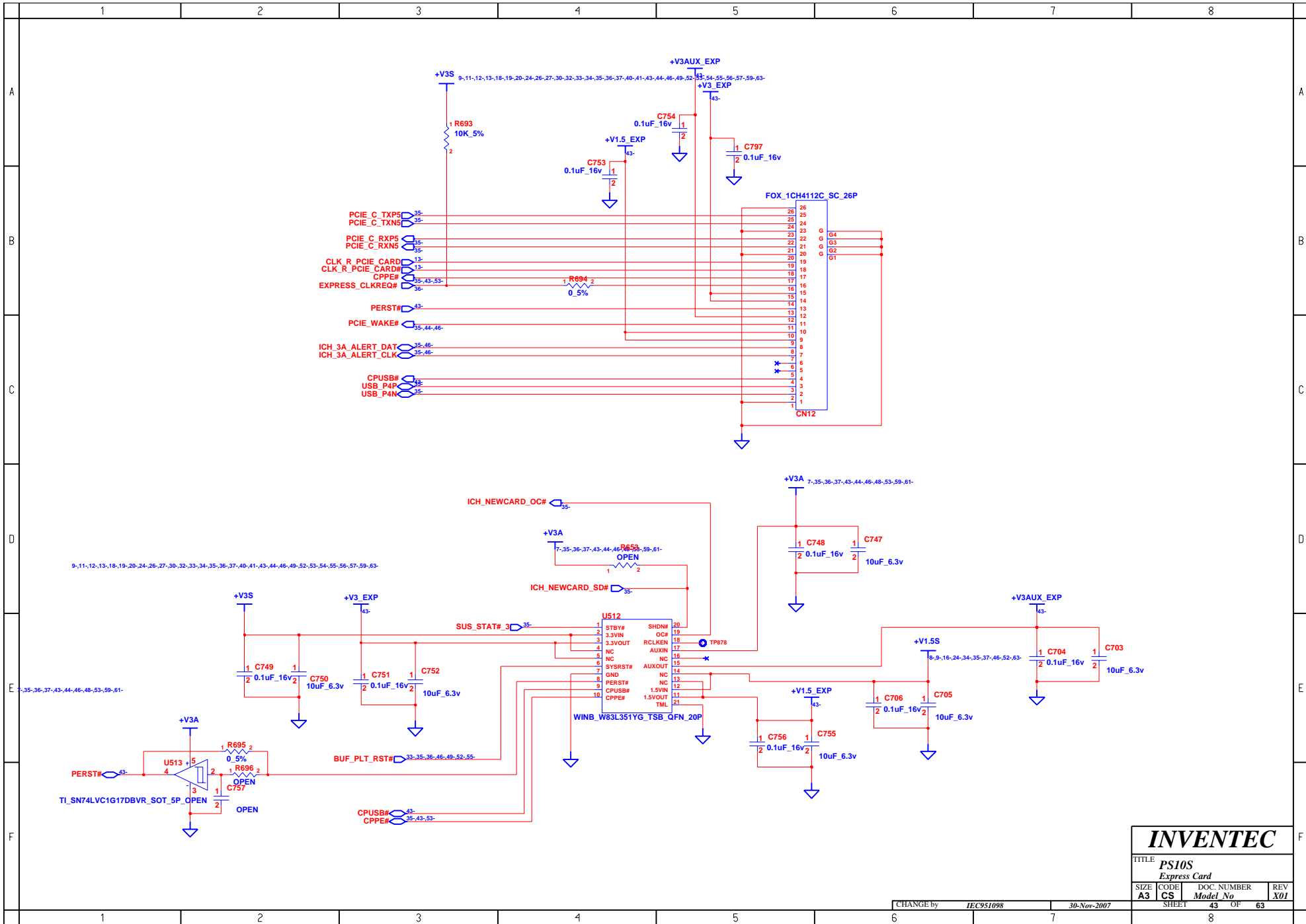

INVENTEC			
TITLE PS10S Express Card			
SIZE A3	CODE CS	DOC. NUMBER <i>Model No</i>	REV X01
CHANGE by <i>IEC951098</i>		30-Nov-2007	
SHEET 43		OF 63	

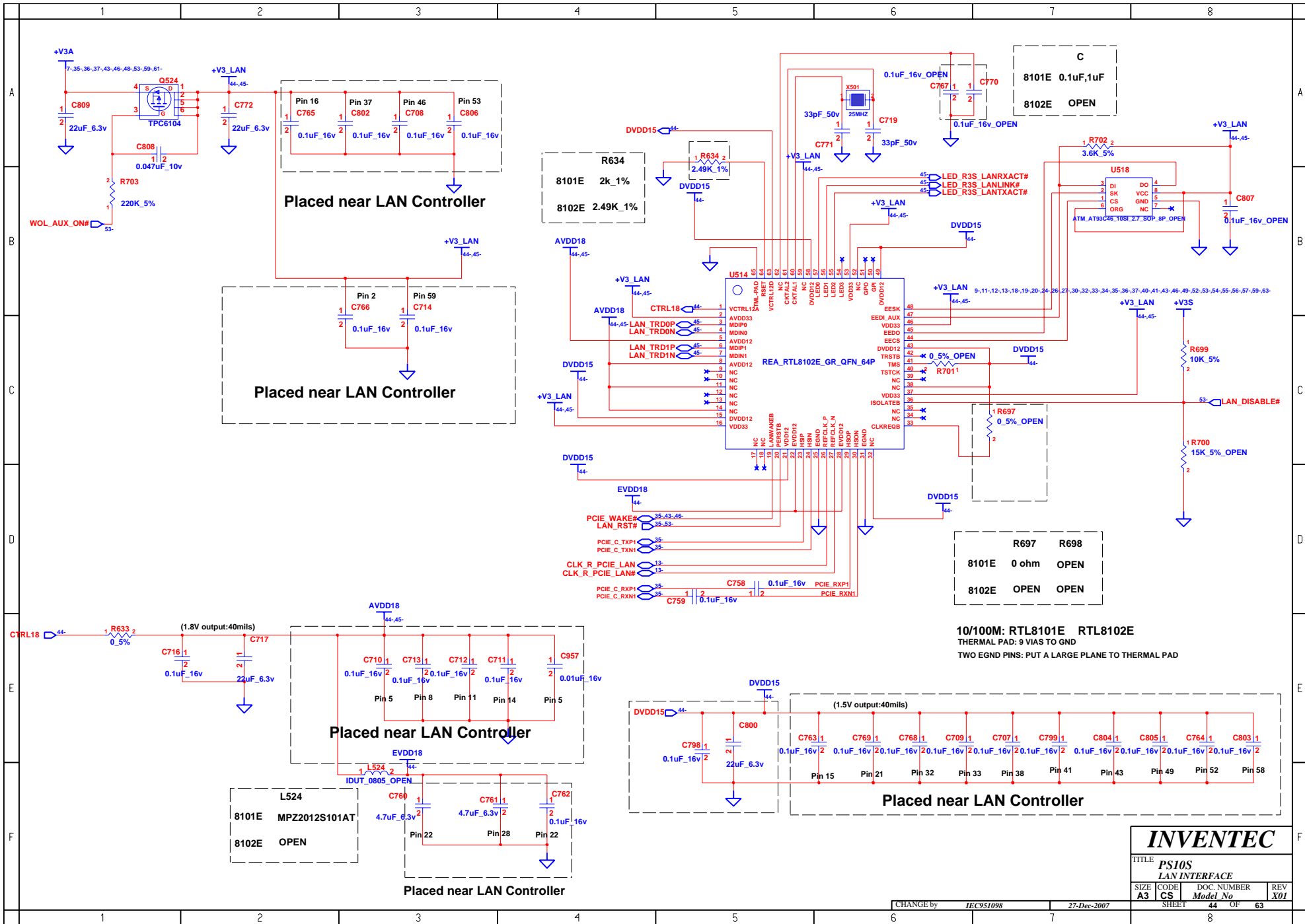

Placed near LAN Controller

Placed near LAN Controller

Placed near LAN Controller

Placed near LAN Controller

10/100M: RTL8101E RTL8102E
THERMAL PAD: 9 VIAS TO GND
TWO EGGD PINS: PUT A LARGE PLANE TO THERMAL PAD

R697	R698
8101E 0 ohm	OPEN
8102E OPEN	OPEN

INVENTEC

TITLE			
PS10S LAN INTERFACE			
SIZE	CODE	DOC NUMBER	REV
A3	CS	Model No	X01

CHANGE by IEC951098 27-Dec-2007

SHEET 44 OF 63

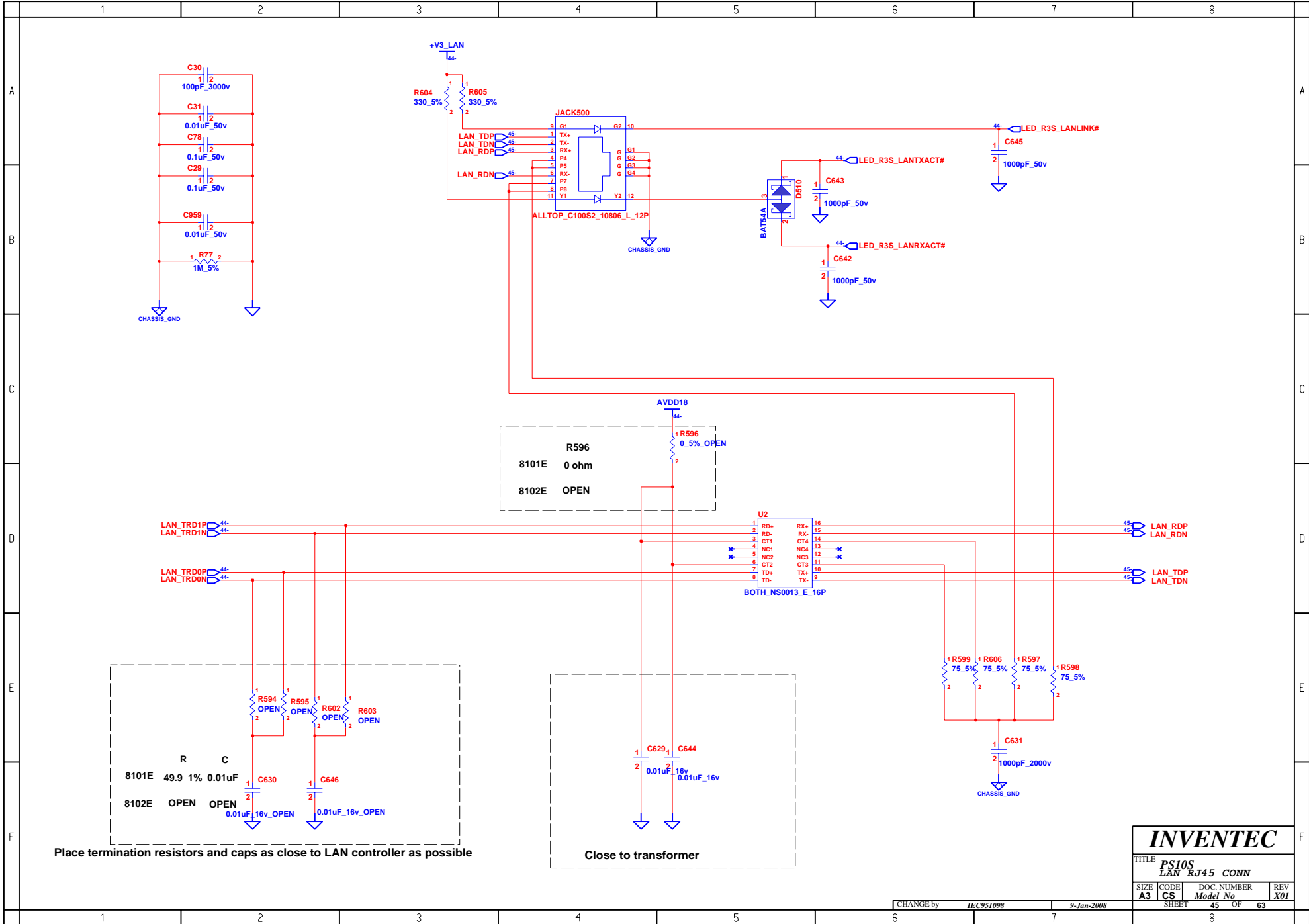

Place termination resistors and caps as close to LAN controller as possible

Close to transformer

INVENTEC

TITLE **PS10S LAN RJ45 CONN**

SIZE	CODE	DOC. NUMBER	REV
A3	CS	Model No	X01

CHANGE by IEC951098 9-Jan-2008

SHEET 45 OF 63

Robson

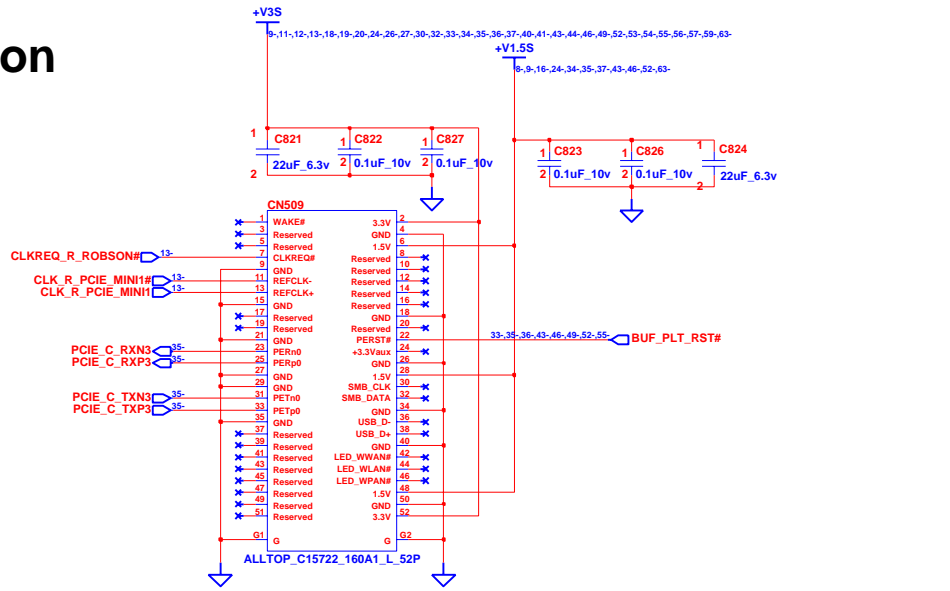

Wireless & Debug card

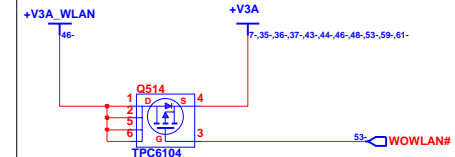
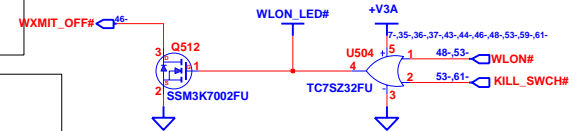
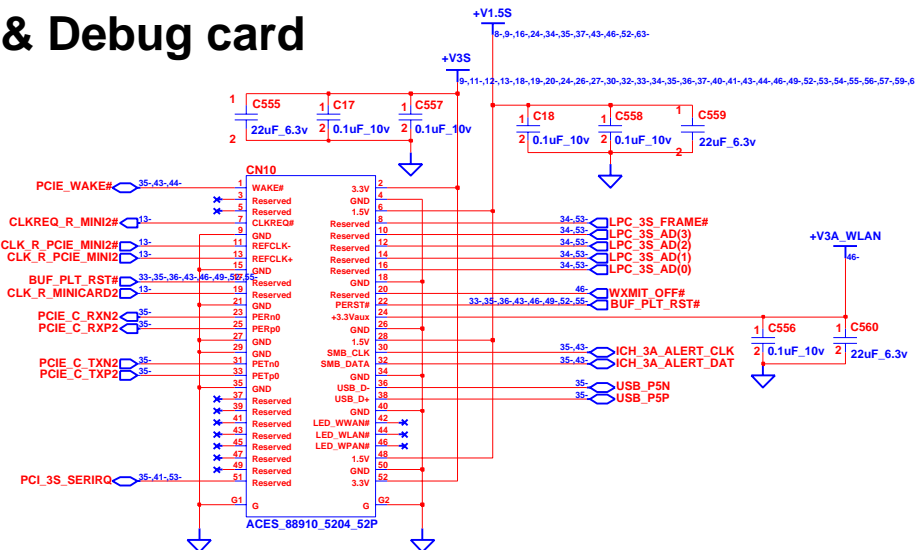

INVENTEC

TITLE			
PS10S			
Robson & WLAN			
SIZE	CODE	DOC. NUMBER	REV
A3	CS	Model No	X01
SHEET		OF	
46		63	

SATA HDD01

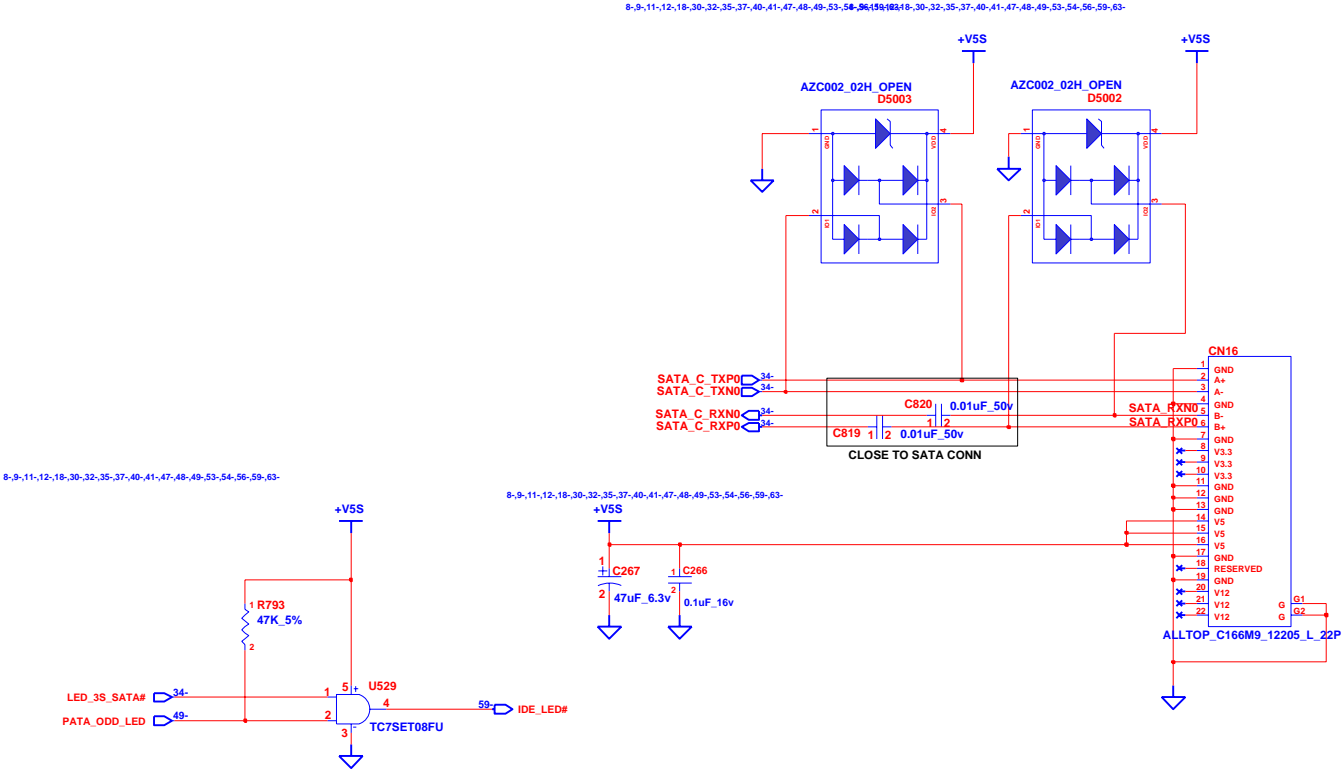

INVENTEC

TITLE			
PS10S			
SATA HDD CONN			
SIZE	CODE	DOC. NUMBER	REV
A3	CS	Model No	X01

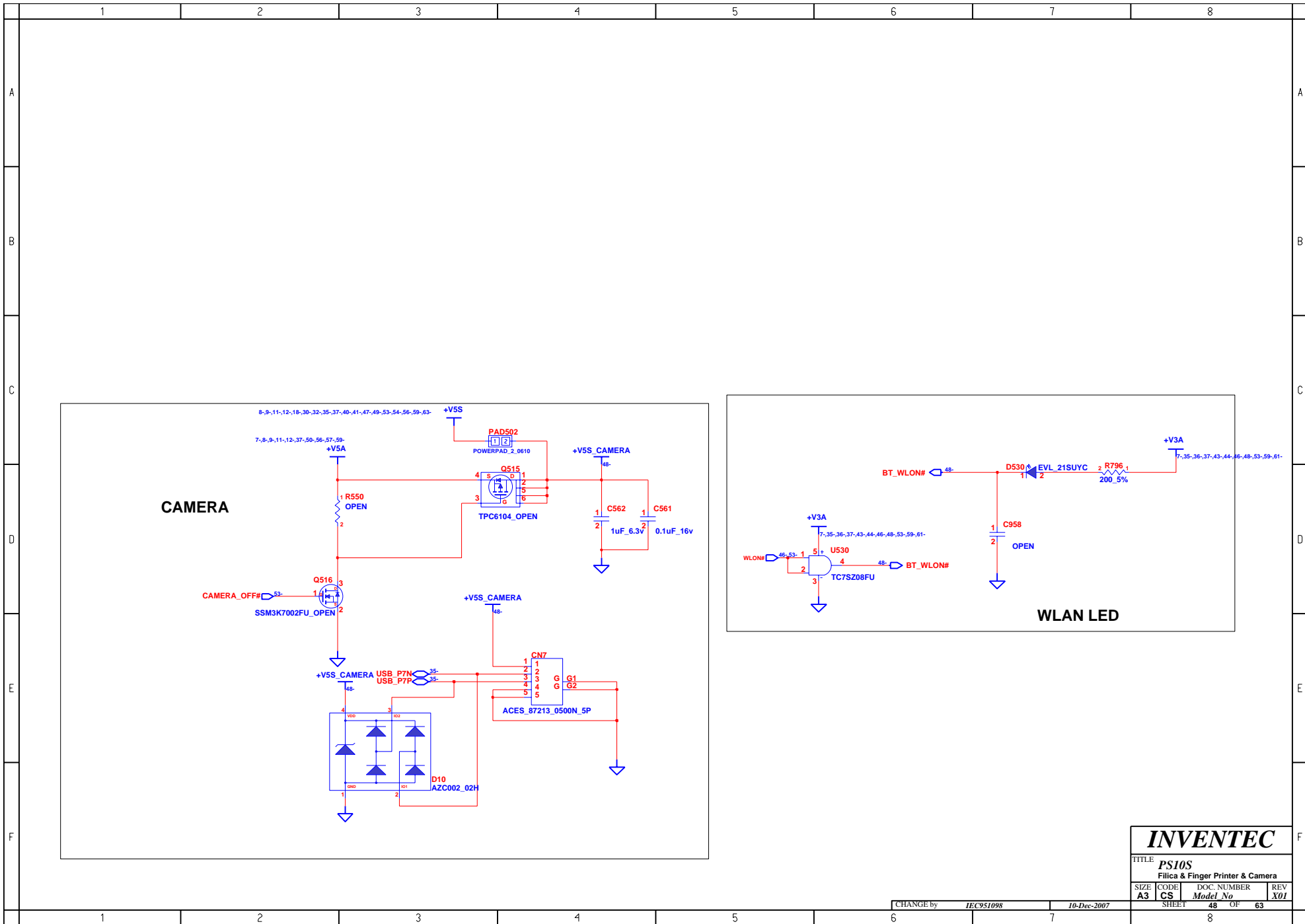

INVENTEC			
TITLE PS10S			
Filica & Finger Printer & Camera			
SIZE A3	CODE CS	DOC. NUMBER Model No	REV X01
CHANGE by IEC951098		10-Dec-2007	
SHEET 48		OF 63	

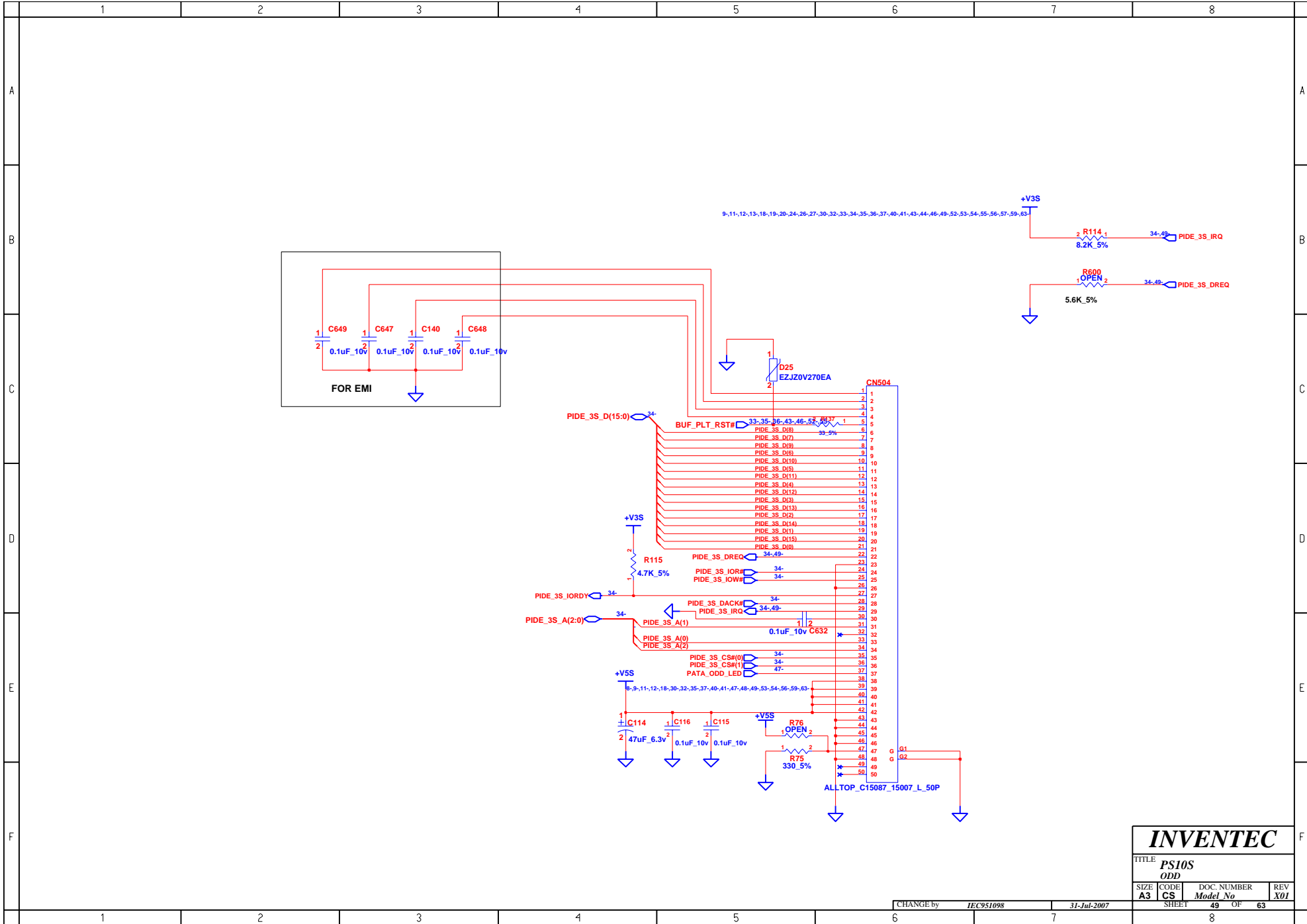

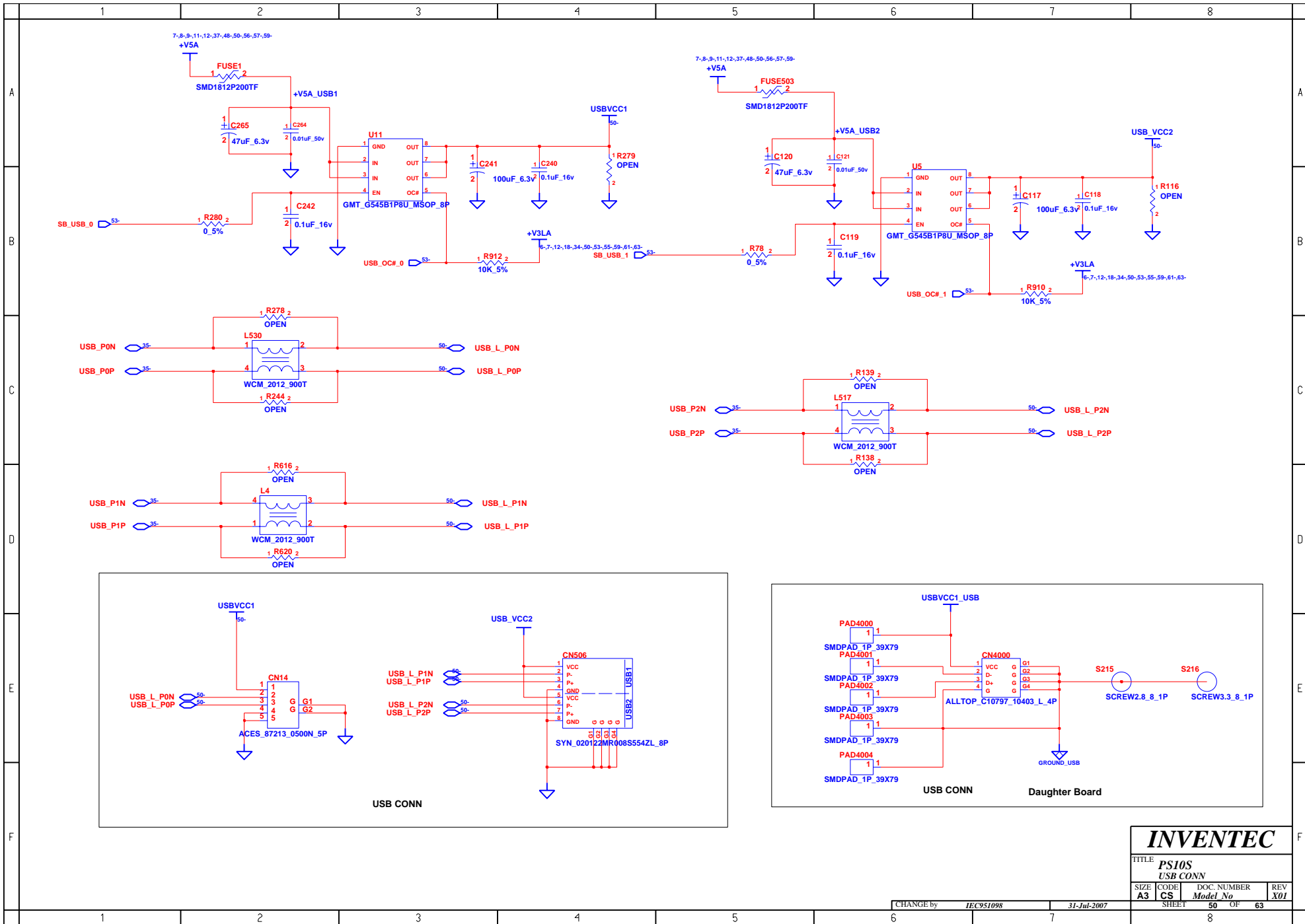

INVENTEC

TITLE			
PS10S			
USB CONN			
SIZE	CODE	DOC. NUMBER	REV
A3	CS	Model No	X01

BLANK

INVENTEC			
TITLE PS10S BLUETOOTH			
SIZE A3	CODE CS	DOC. NUMBER <i>Model No.</i>	REV X01
CHANGE by <i>IEC951098</i>		30-Nov-2007	
SHEET		51	OF 63

	1	2	3	4	5	6	7	8	
A									A
B									B
C									C
D									D
E									E
F									F
	1	2	3	4	5	6	7	8	

HD_DVD

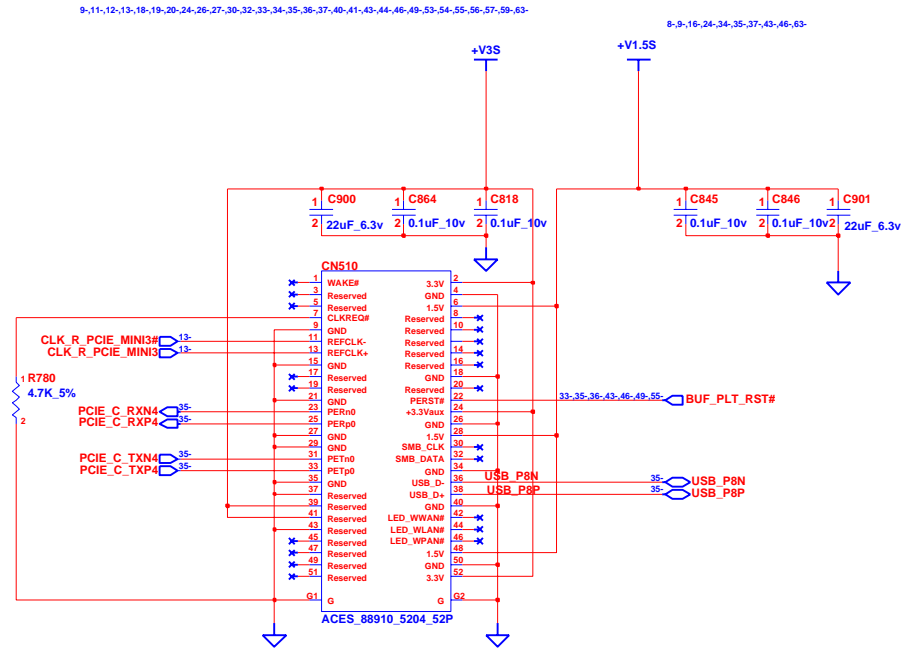

INVENTEC

TITLE			
PS10S			
3G_SIM			
SIZE	CODE	DOC. NUMBER	REV
A3	CS	Model No	X01

CHANGE by IEC951098 27-Dec-2007

SHEET 52 OF 63

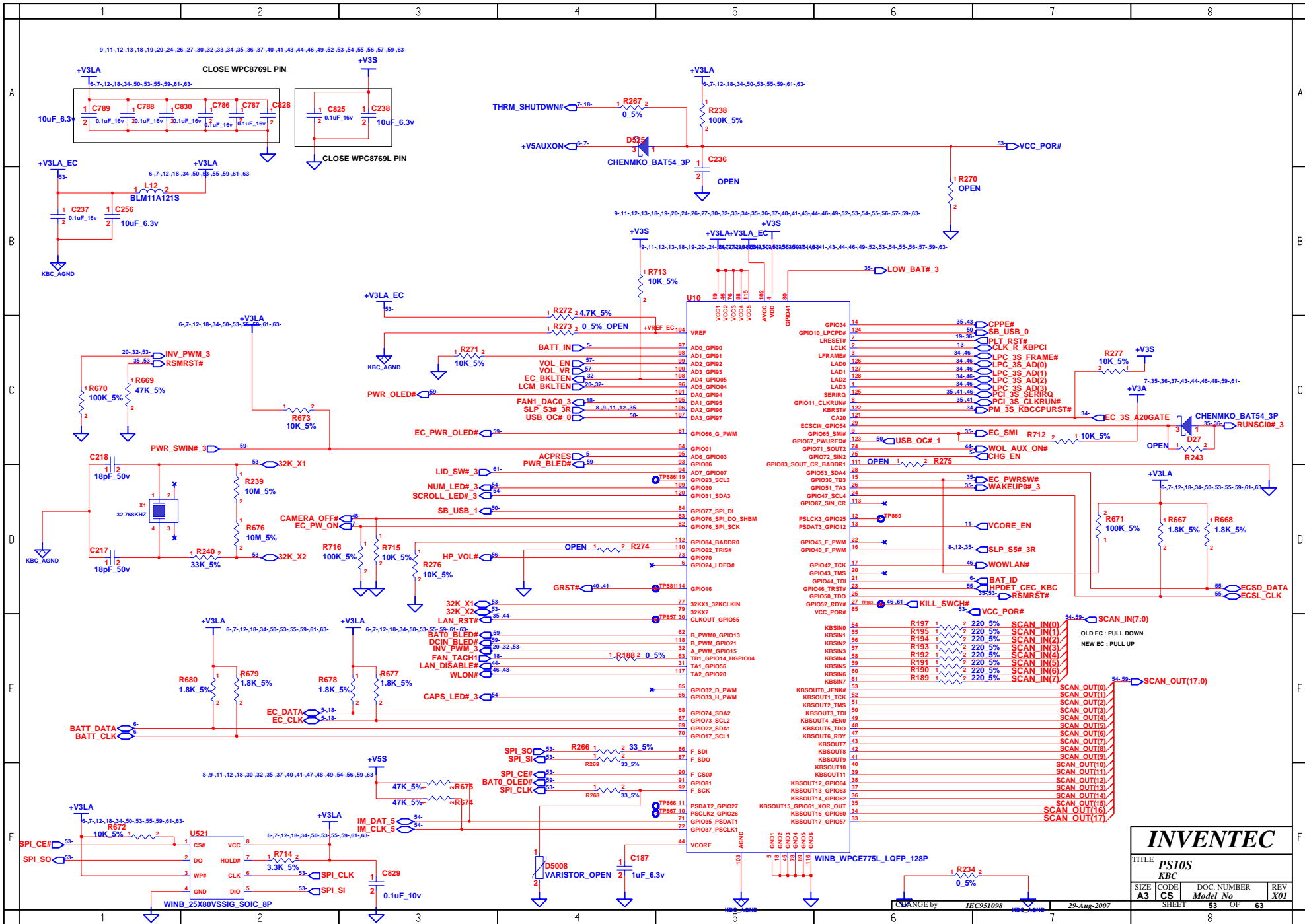

INVENTEC			
TITLE PS10S KBC			
SIZE A3	CODE CS	DOC. NUMBER Model No	REV X01
CHANGE by IEC951098		29-Aug-2007	
SHEET 53		OF 63	

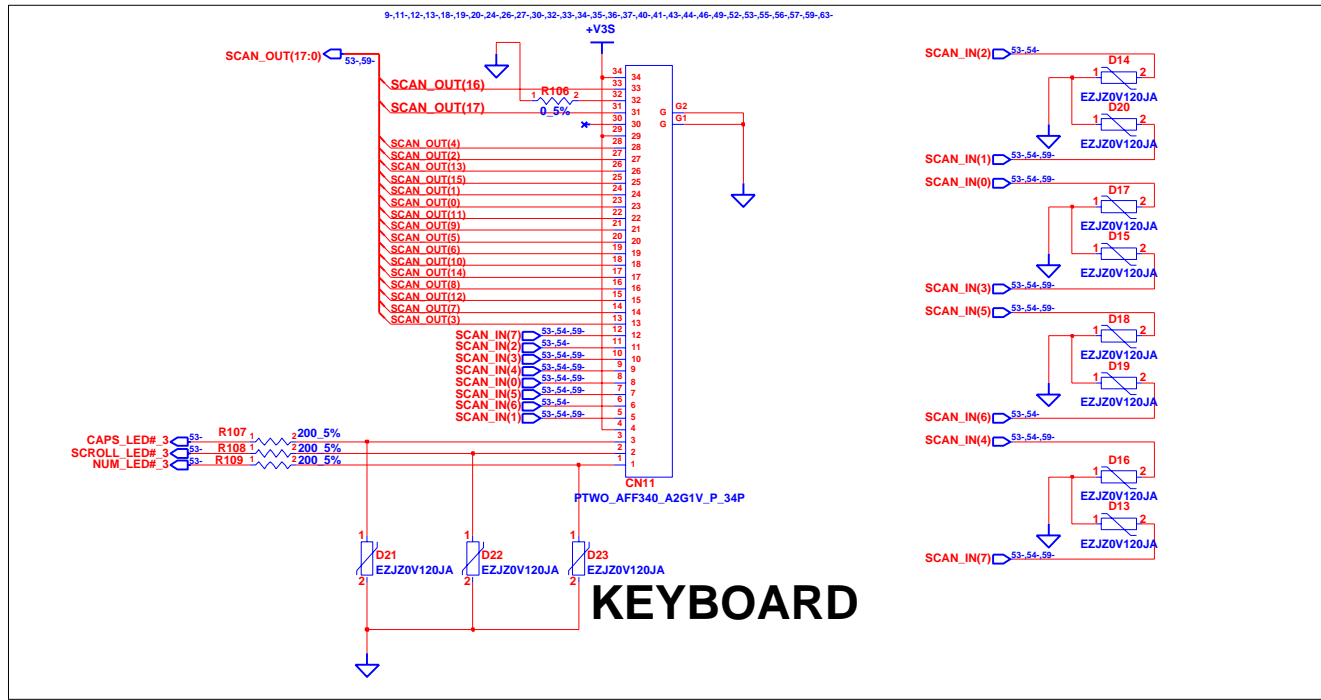

KEYBOARD

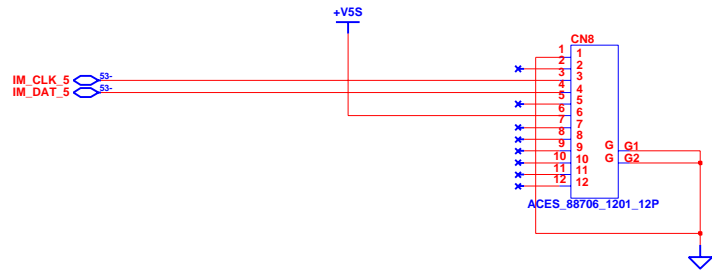

INVENTEC			
TITLE PS10S INT.KBC/POINT DEVICES			
SIZE A3	CODE CS	DOC. NUMBER Model No	REV X01
CHANGE by IEC951098		10-Dec-2007	
SHEET		54 OF 63	

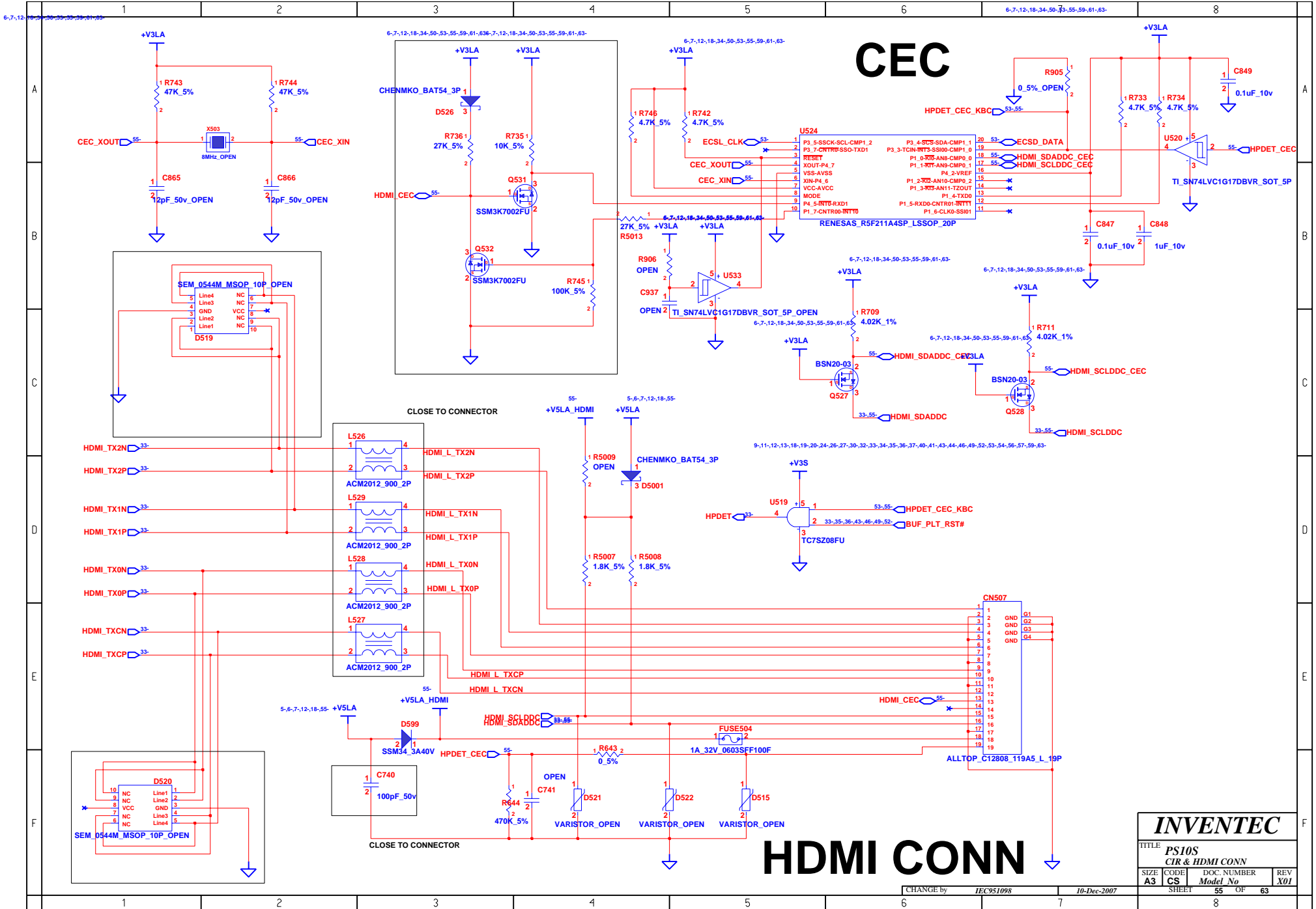

INVENTEC			
TITLE PS10S			
CIR & HDMI CONN			
SIZE A3	CODE CS	DOC. NUMBER	REV X01
SHEET 55		OF 63	

CHANGE by **IEC951098** 10-Dec-2007

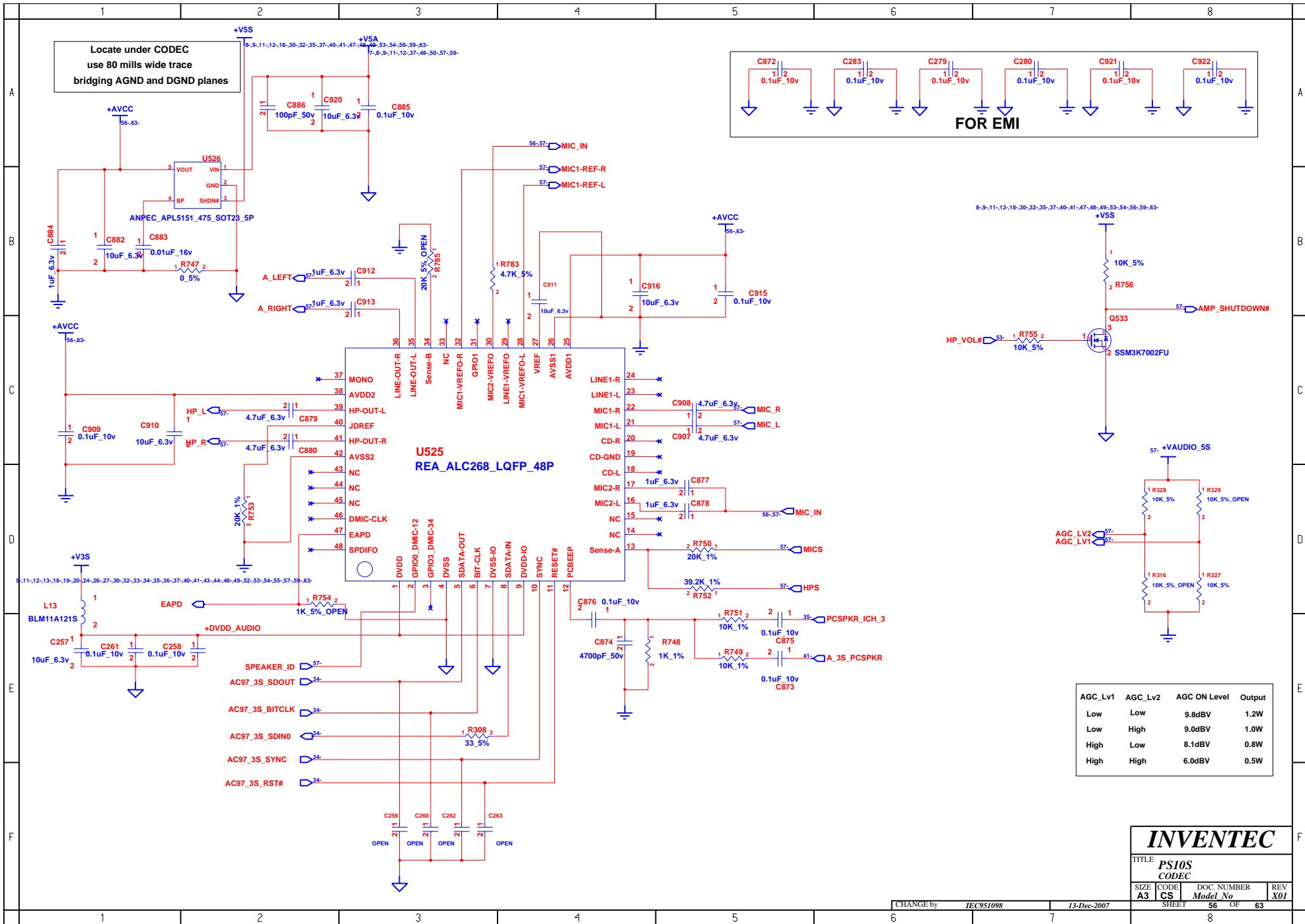

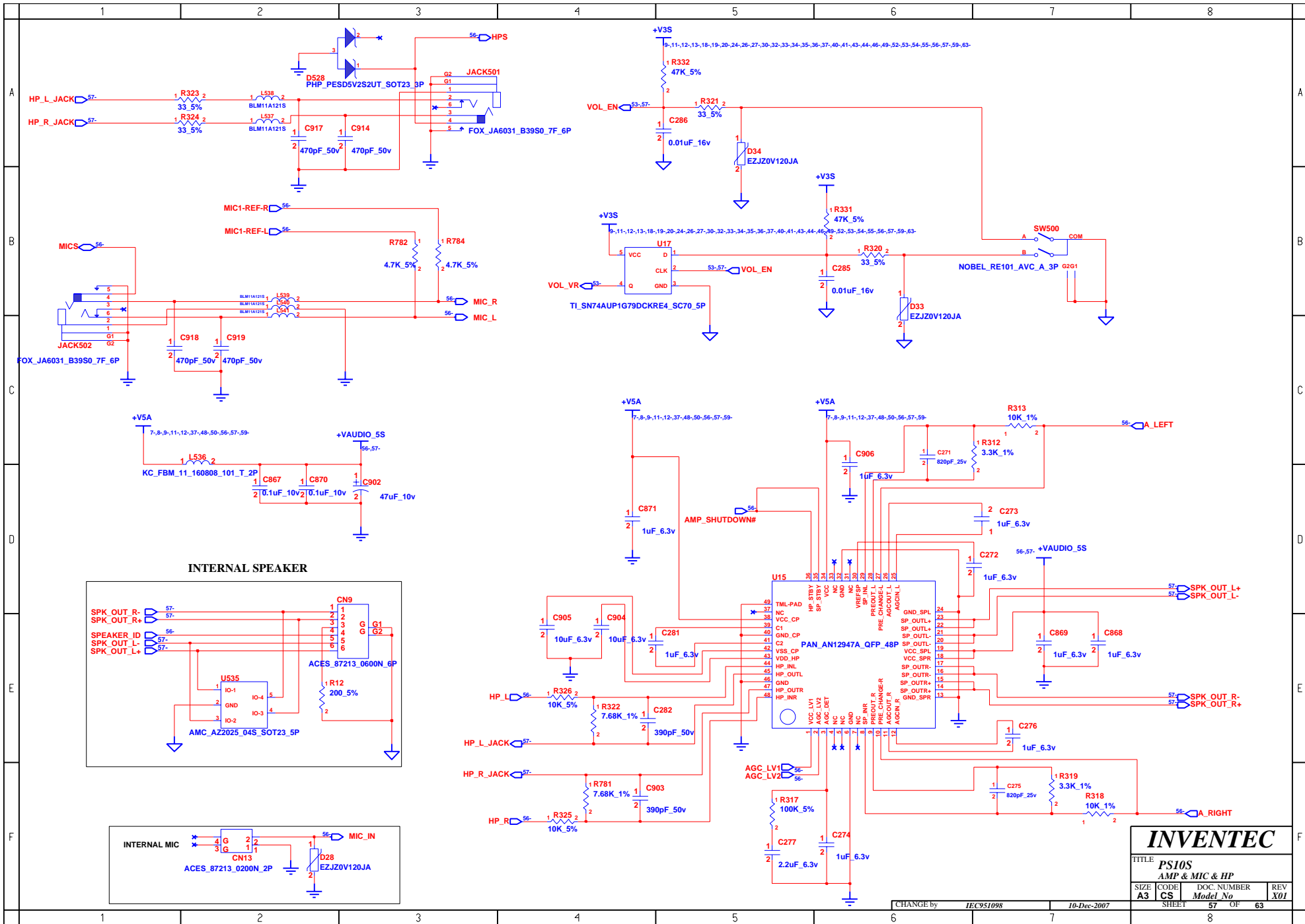

INVENTEC			
TITLE PS10S AMP & MIC & HP			
SIZE A3	CODE CS	DOC NUMBER Model No	REV X01
CHANGE by IEC951098		10-Dec-2007	
SHEET 57		OF 63	

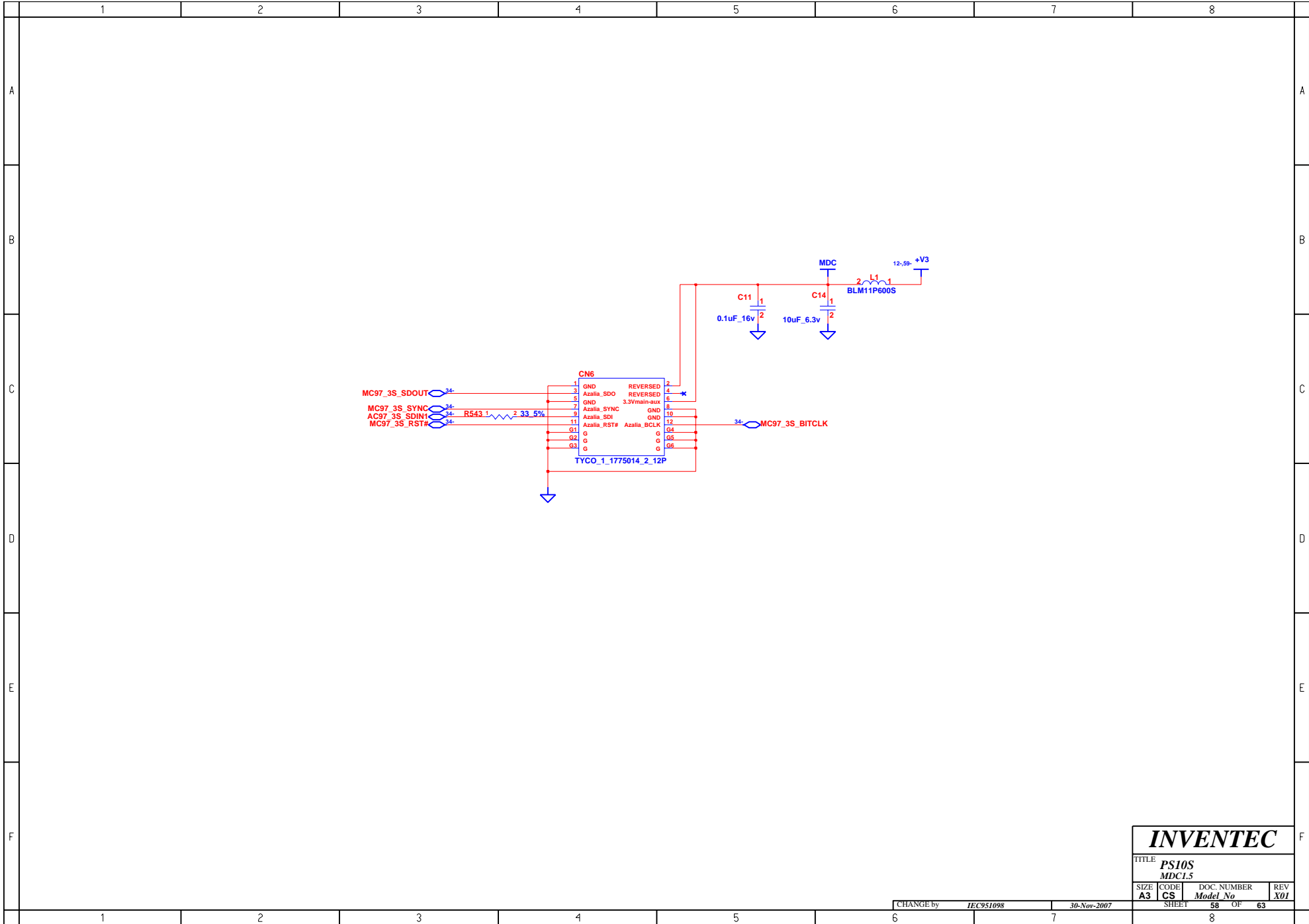

INVENTEC

TITLE
PS10S
MDCL5

SIZE A3	CODE CS	DOC. NUMBER <i>Model No</i>	REV X01
-------------------	-------------------	--------------------------------	-------------------

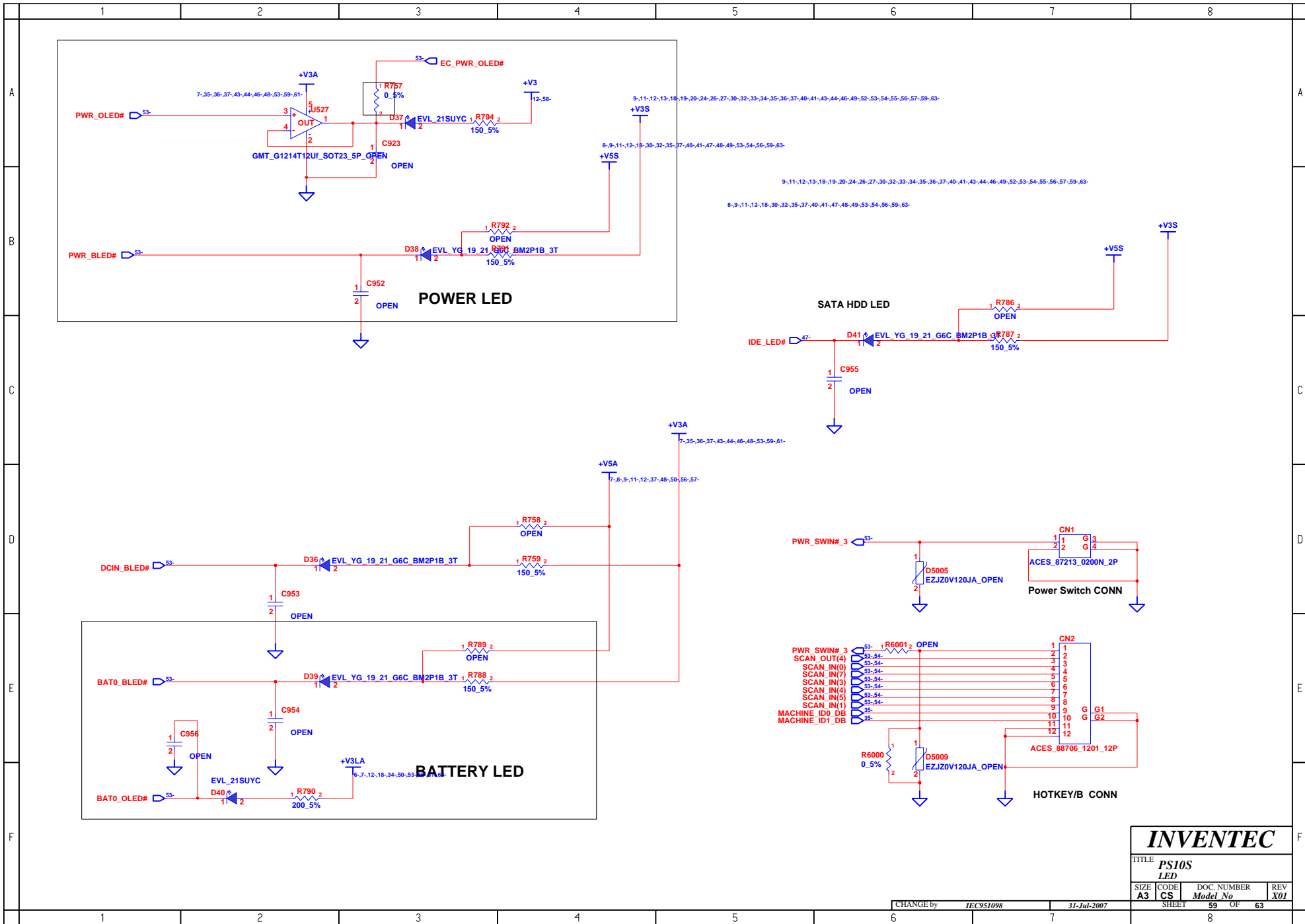

INVENTEC

TITLE			
PS10S			
LED			
SIZE	CODE	DOC. NUMBER	REV
A3	CS	Model No	X01

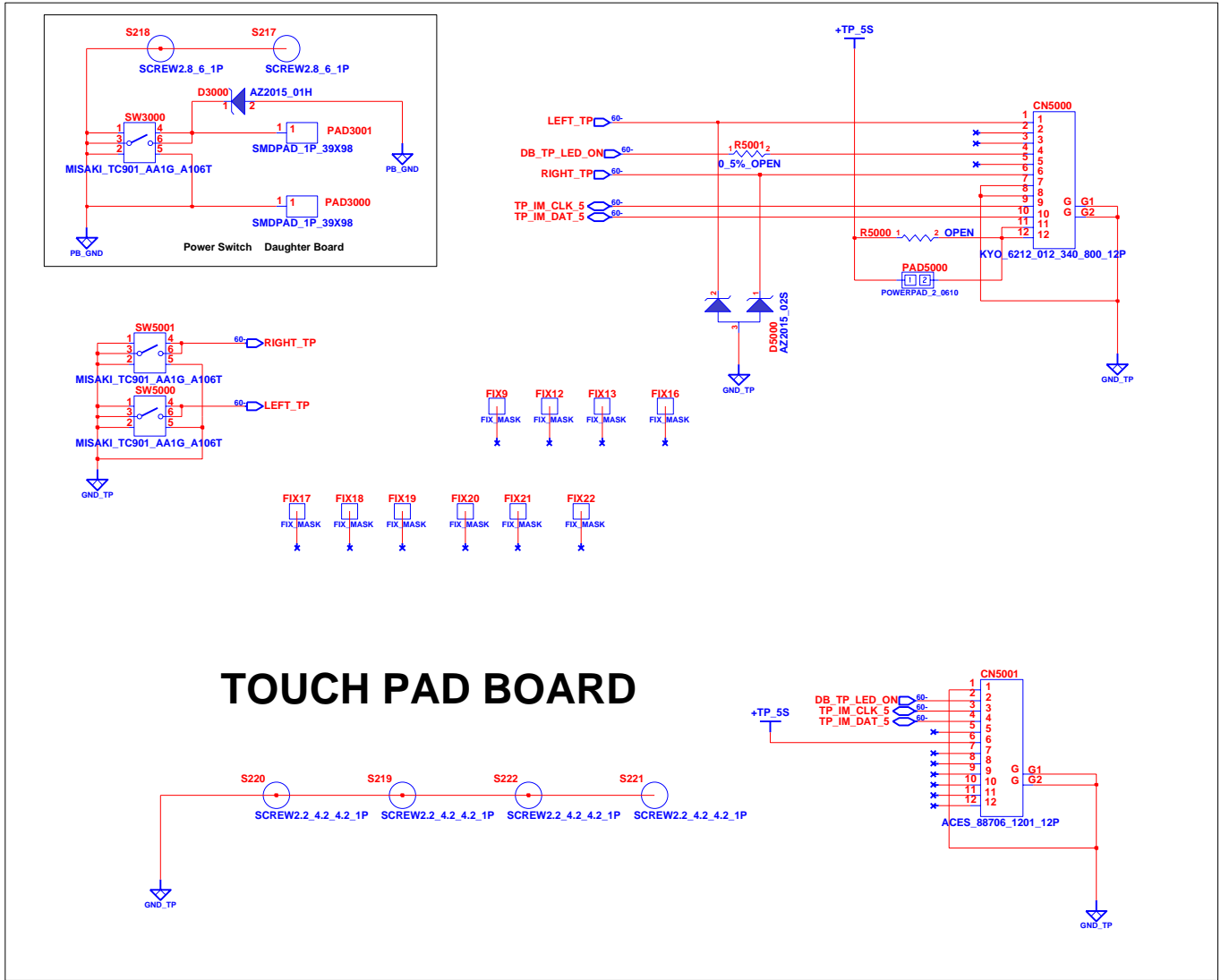

TOUCH PAD BOARD

INVENTEC

TITLE			
PS10S			
Touch Pad Board			
SIZE	CODE	DOC. NUMBER	REV
A3	CS	Model No	X01

CHANGE by IEC951098 5-Nov-2007

SHEET 60 OF 63

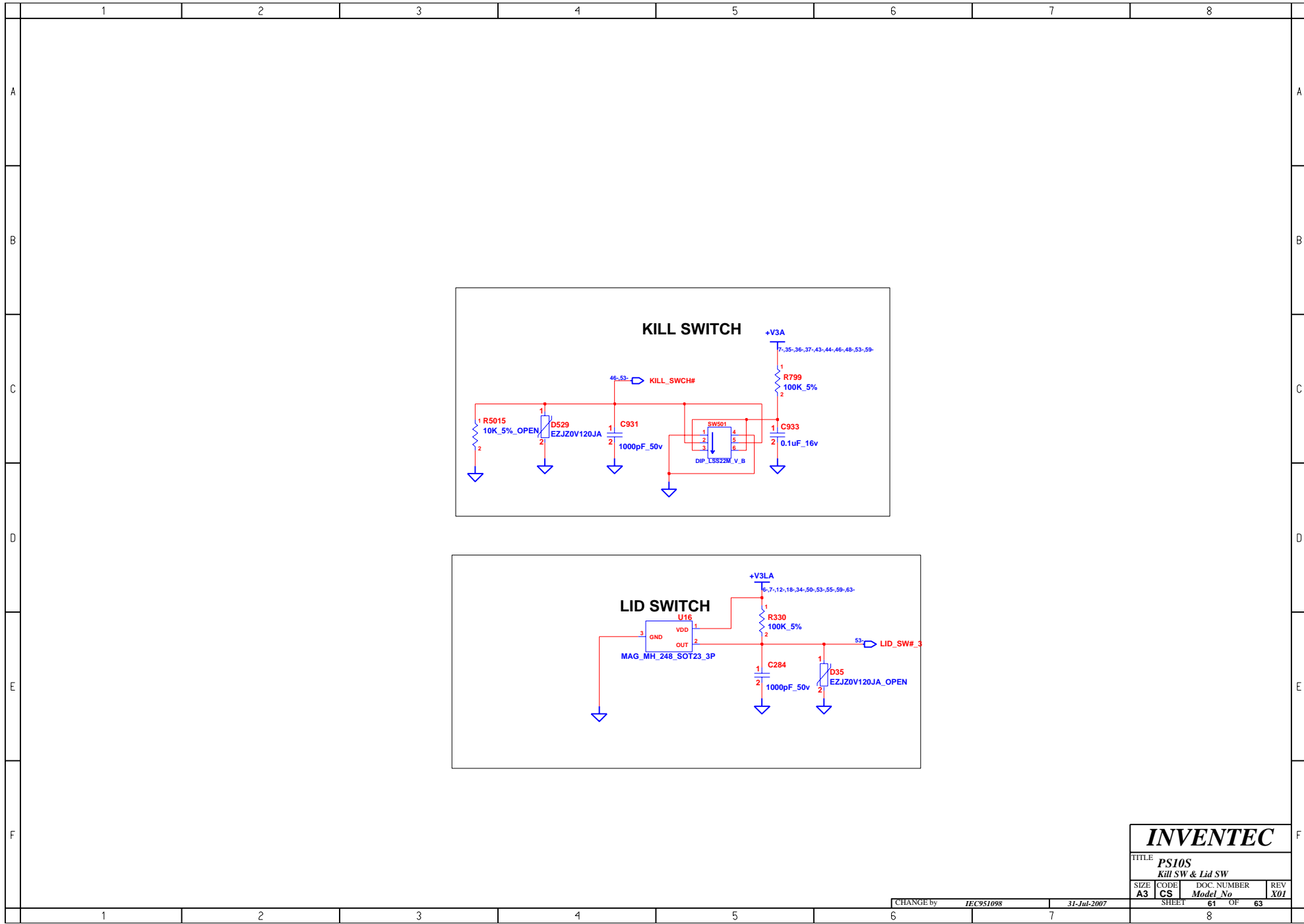

INVENTEC			
TITLE PS10S Kill SW & Lid SW			
SIZE A3	CODE CS	DOC. NUMBER Model No	REV X01
CHANGE by IEC951098		31-Jul-2007	
SHEET 61 OF 63		8	

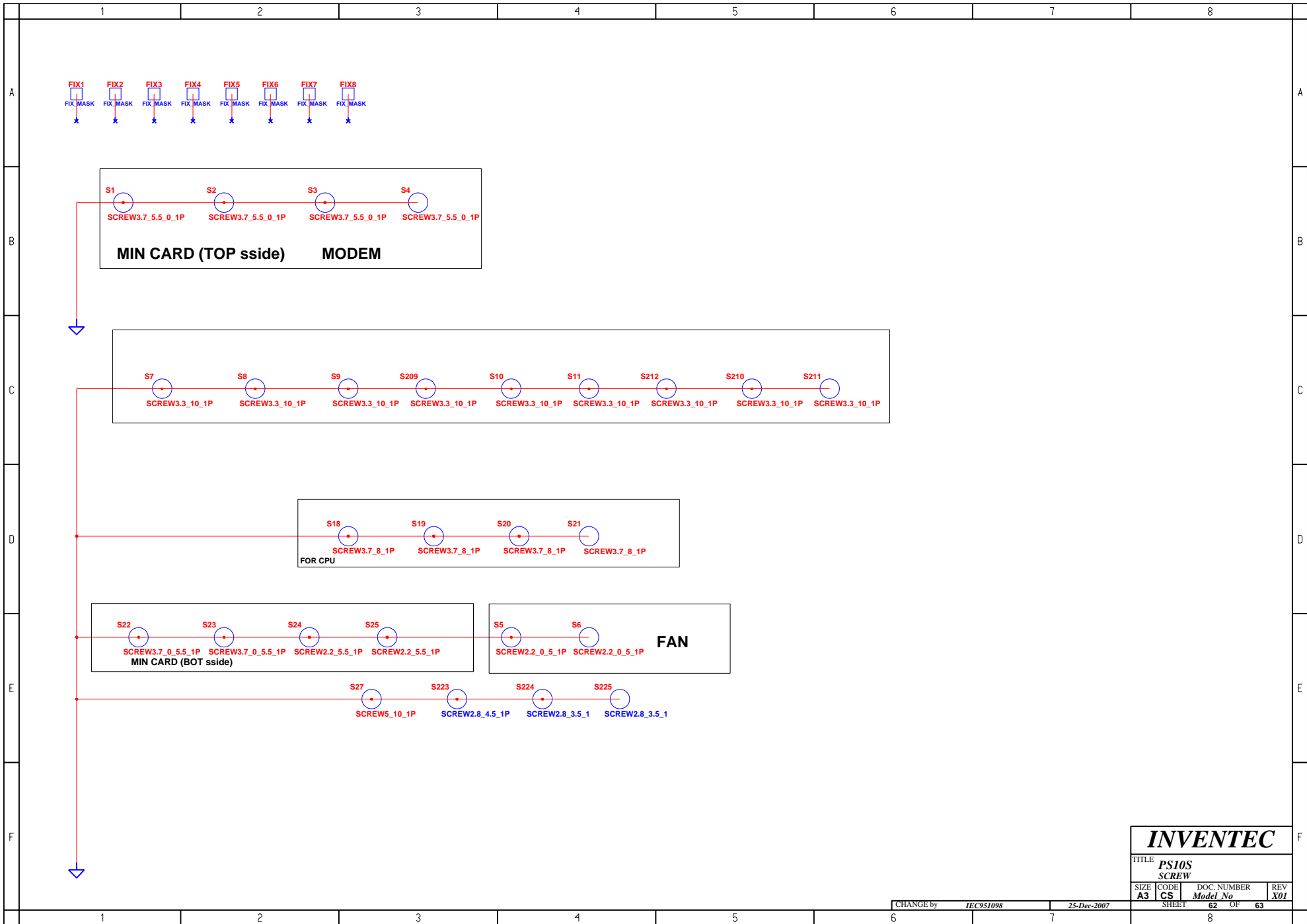

INVENTEC

TITLE
**PS10S
 SCREW**

SIZE A3	CODE CS	DOC. NUMBER <i>Model No</i>	REV X01
-------------------	-------------------	--------------------------------	-------------------

CHANGE by *IEC951098* *25-Dec-2007*

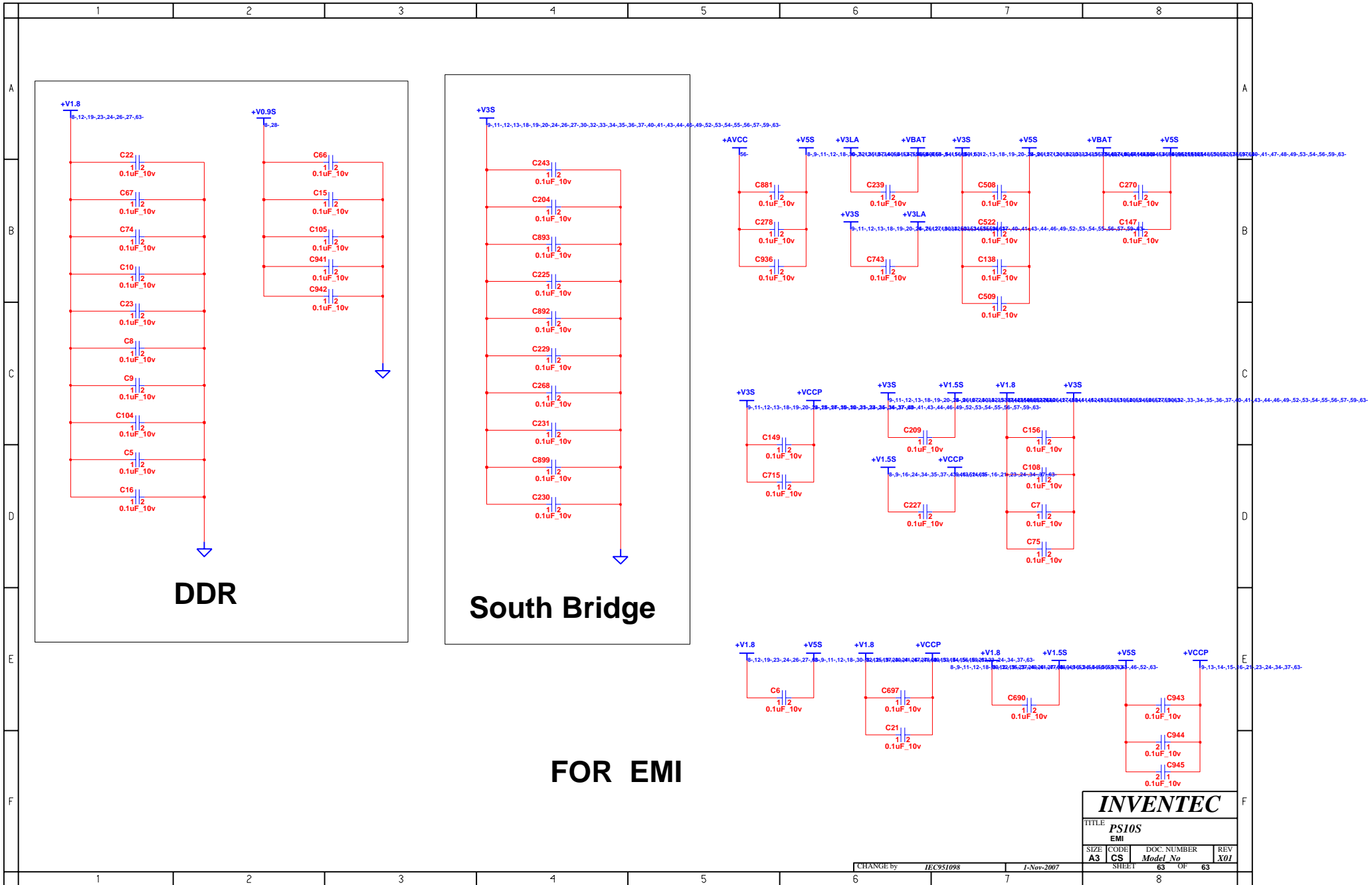

INVENTEC			
TITLE PS10S			
EMI			
SIZE A3	CODE CS	DOC. NUMBER <i>Model No</i>	REV X01
CHANGE by IECVS1098		I-Nov-2007	
SHEET 1		63 OF 63	